

Characterizing Single-Phase LArTPC Detector Performance With MicroBooNE

Christopher Barnes
University of Michigan

CIPANP 2018
May 30th, 2018
Palm Springs, CA

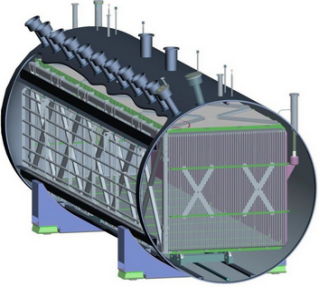

MicroBooNE

MicroBooNE is an important step in LArTPC development in preparation for DUNE!

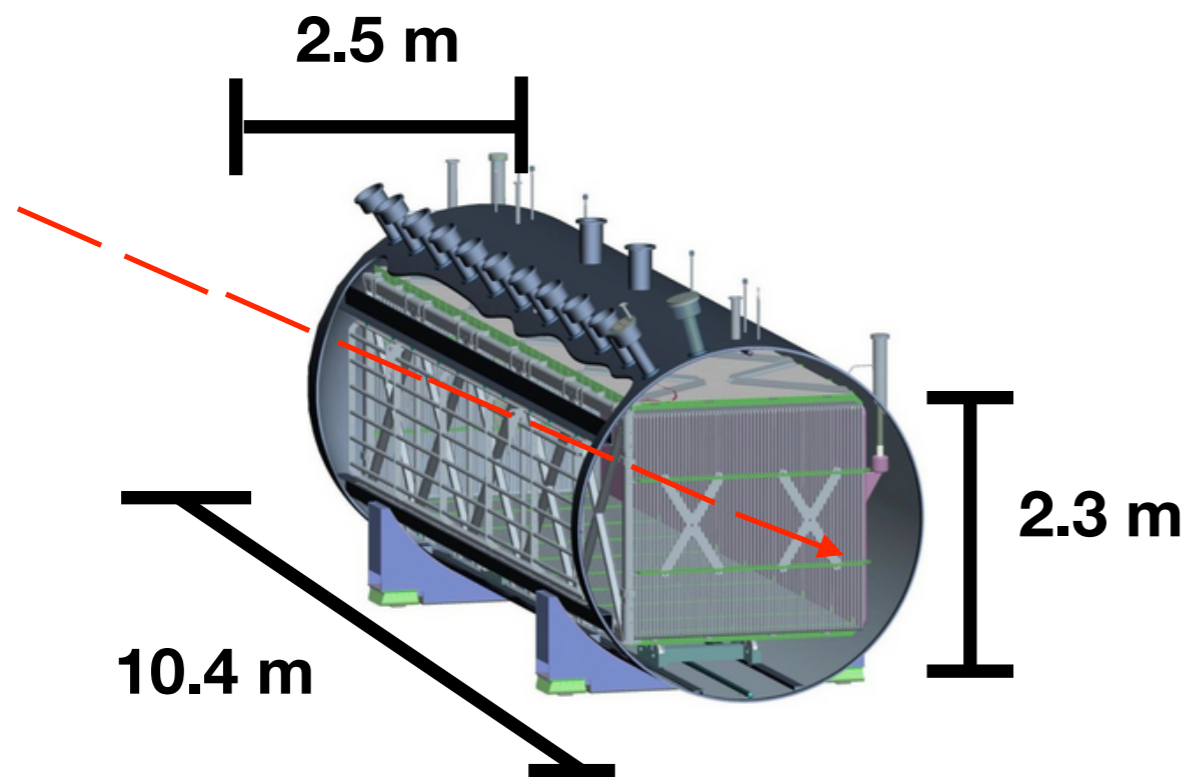

MicroBooNE Detector

Physics Goals of MicroBooNE:

- Investigate the low-energy excess observed by the MiniBooNE experiment.
- Perform novel neutrino-LAr cross section measurements.

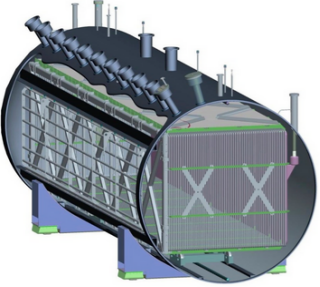

Detector Physics With

MicroBooNE



MicroBooNE serves as a laboratory to study a number of LArTPC detector effects:

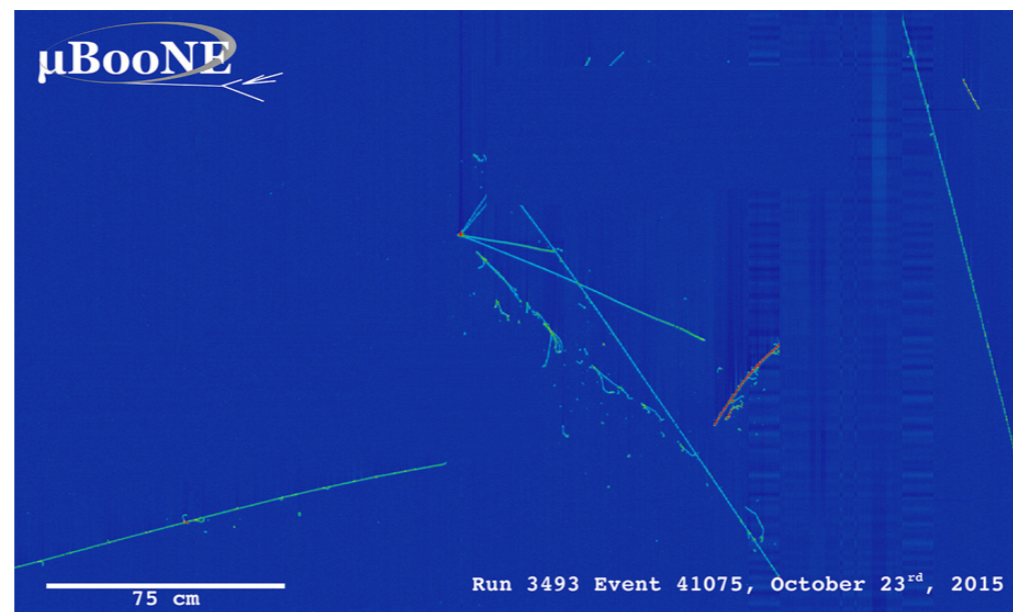
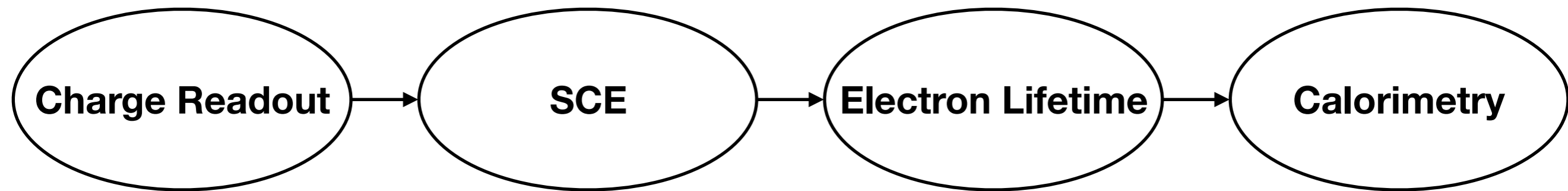

Calibrating and studying all are important for accurate event reconstruction!

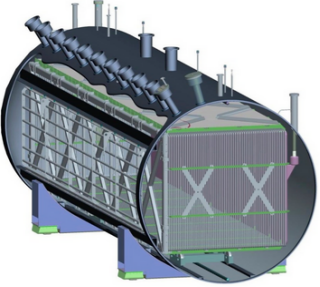

Calibration Sample: Through-Going Muons

We currently have two methods for tagging through-going muons for detector calibration:

1. MuCS (Muon Counter System)

J. Inst. 12 P12030 (2017): <http://iopscience.iop.org/article/10.1088/1748-0221/12/12/P12030>

2. Anode-Piercing/Cathode-Piercing Tracks

MicroBooNE Public Note #28: <http://microboone.fnal.gov/wp-content/uploads/MICROBOONE-NOTE-1028-PUB.pdf>

Tracks Missing TPC
Tracks Intersecting TPC

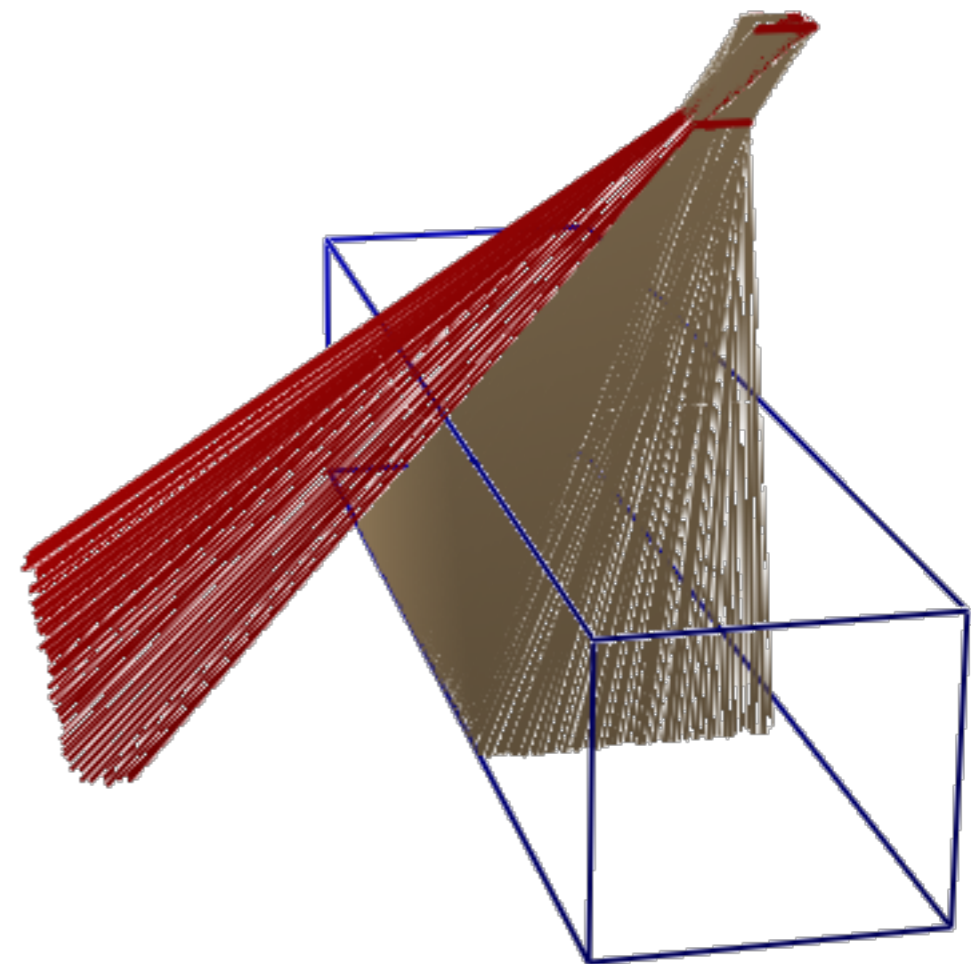

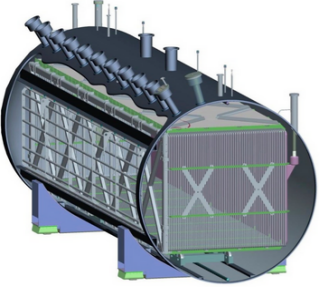

t_0 -Tagging Procedure

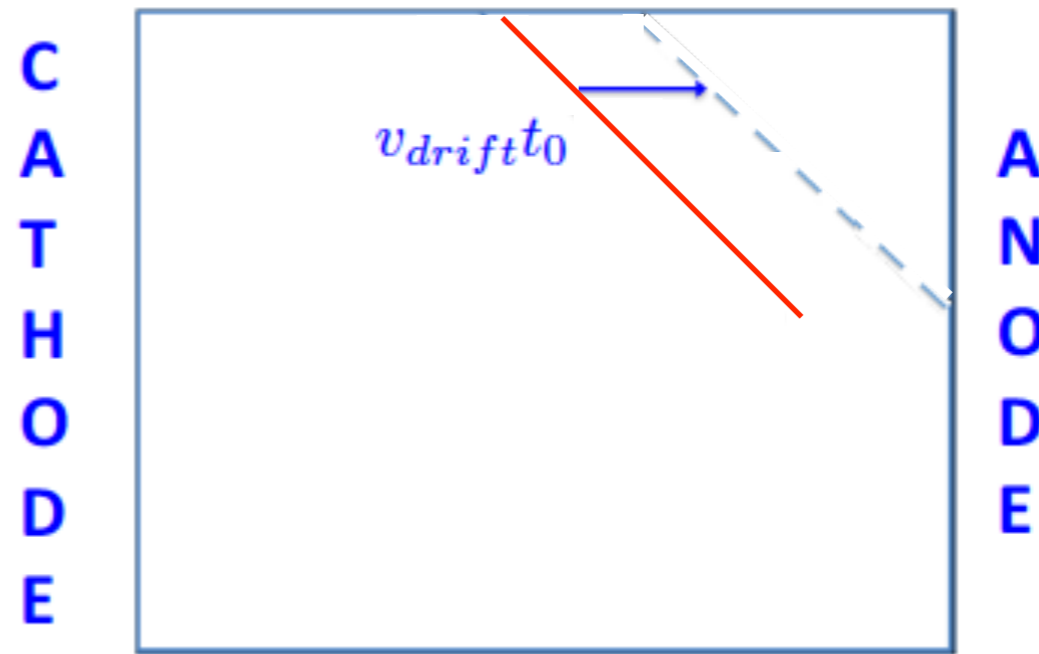
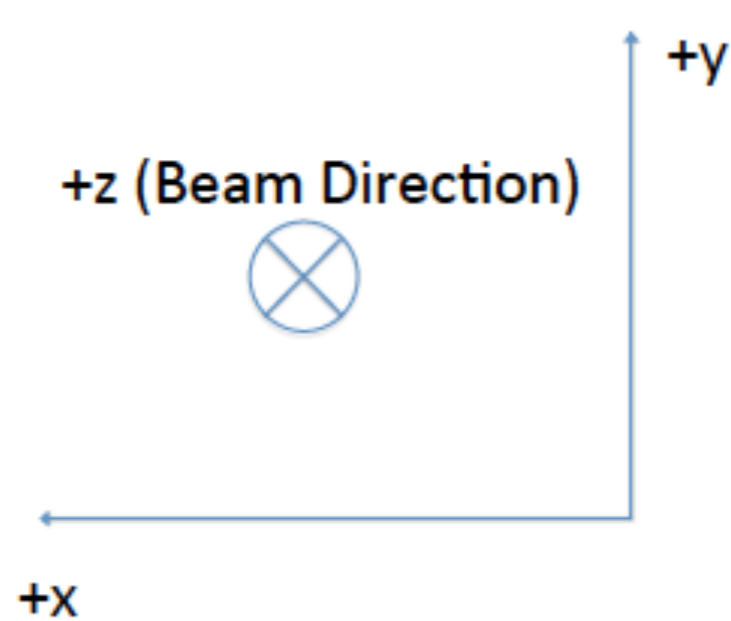

Through-going cosmic ray tracks must have full 3D information available to be used in calibrations.

— : Reconstructed Track
- - - : t_0 - Corrected Track

Cosmic ray tracks that pierce both the anode and the cathode can also be used for detector calibrations.

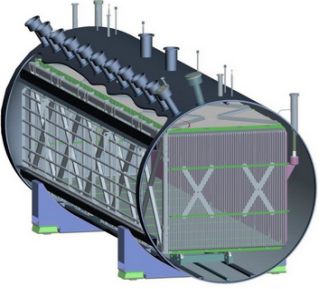

Calibration Sample: Stopping Muons

Stopping muons have a distinct energy loss profile in liquid argon.

Therefore, with a pure sample of these tracks, we can compare to lookup tables to calibrate the dE/dx extrapolation of our detector.

MicroBooNE Event Display: False Color

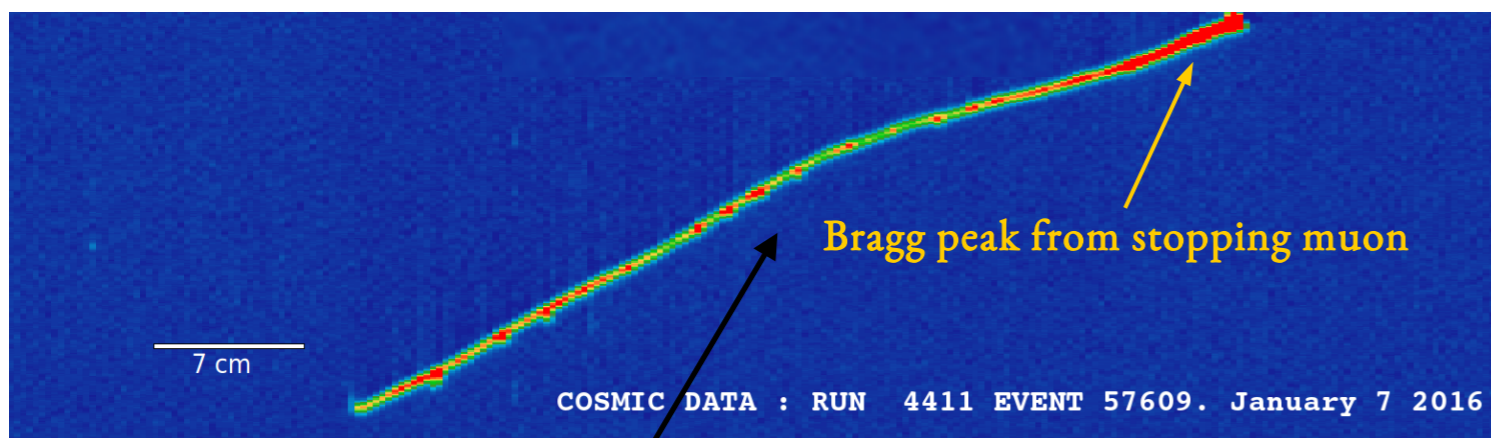

Stopping Muon

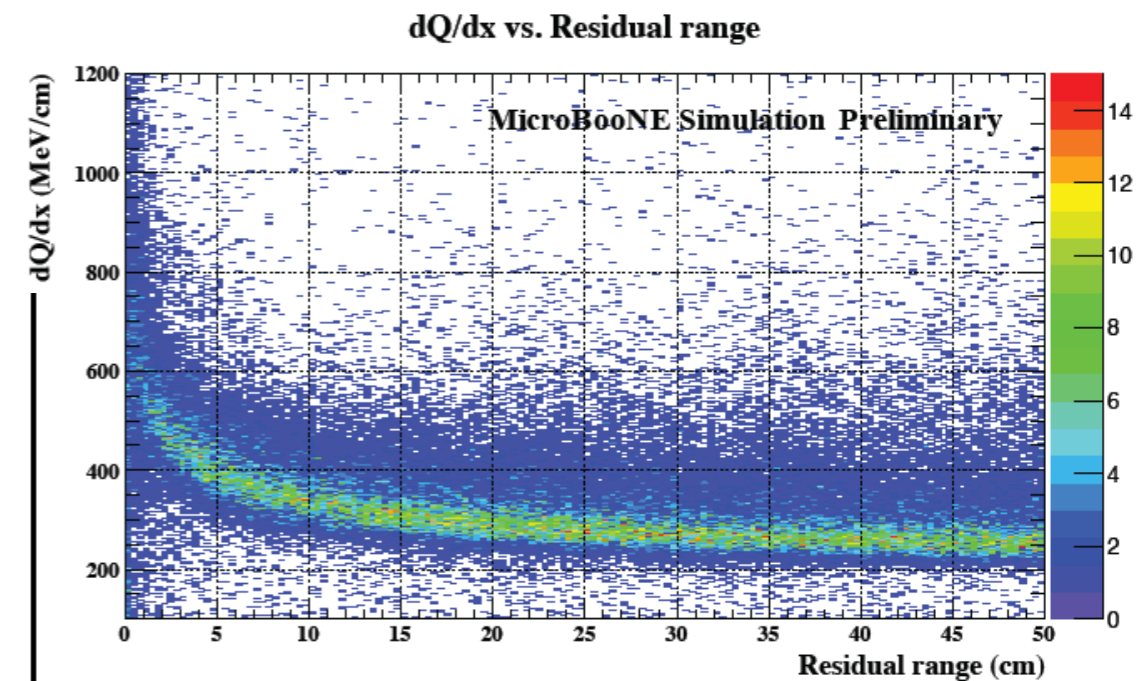

Muon
 dE/dx

Muon
Kinetic Energy

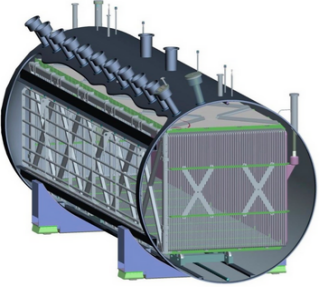

Charge Readout Calibration

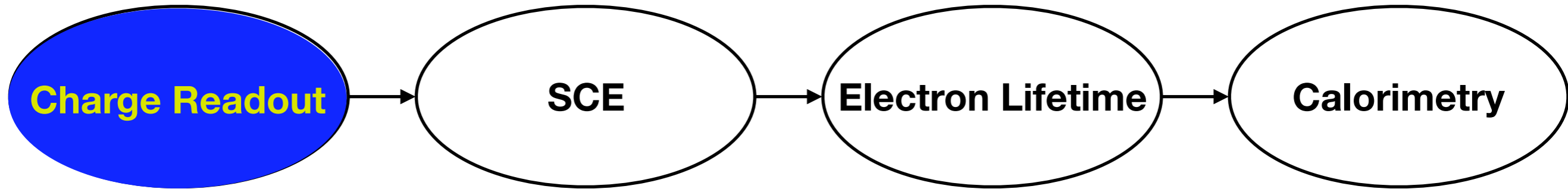

When ionization electrons drift to the anode wire planes, effects of charge readout on the planes must be calibrated for first.

These include:

- Detector Noise (Inherent & TPC-Induced)
- Charge Exchange Between Neighboring Wires

MicroBooNE is the first above-ground LArTPC operating in a neutrino beam!

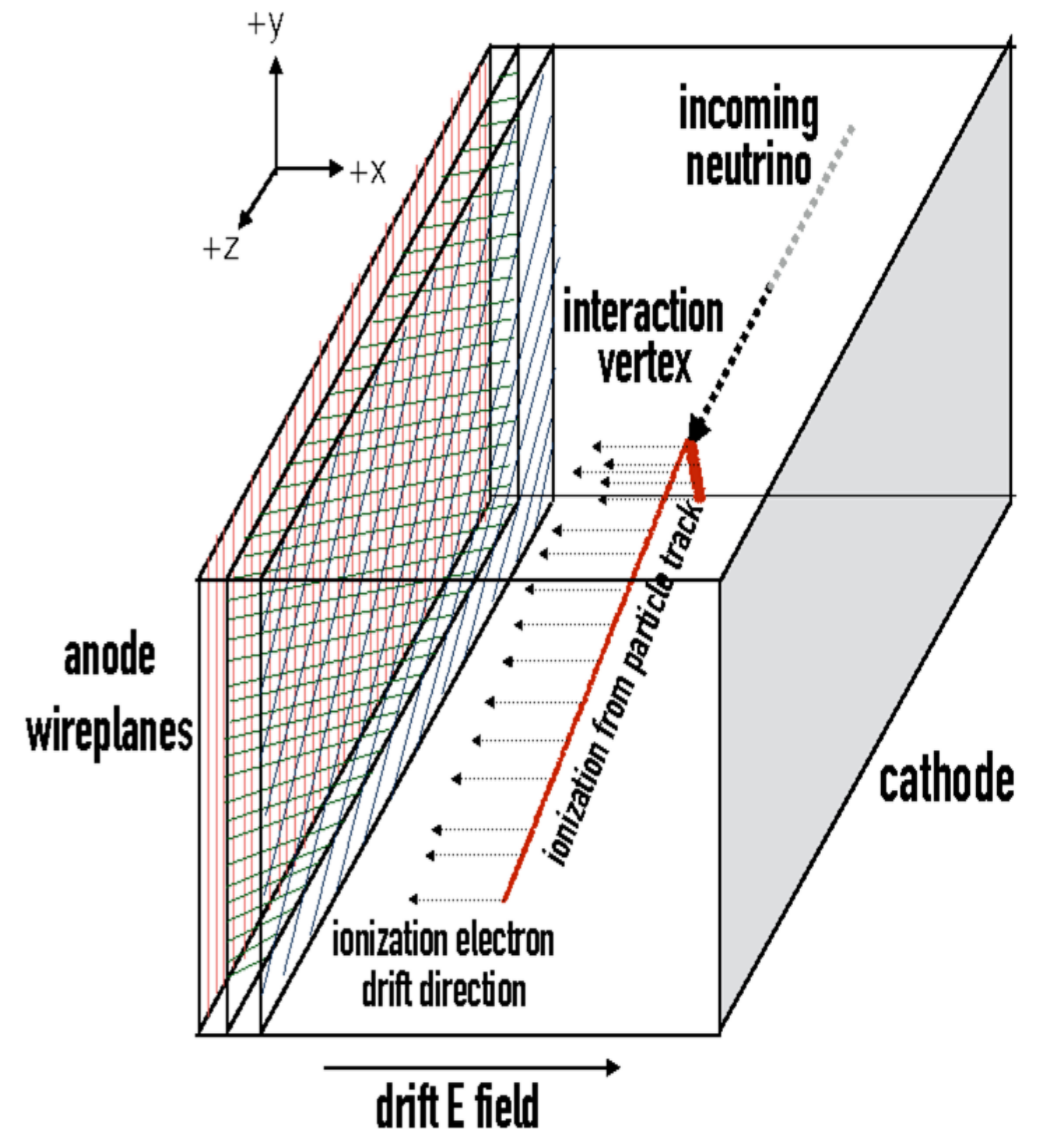

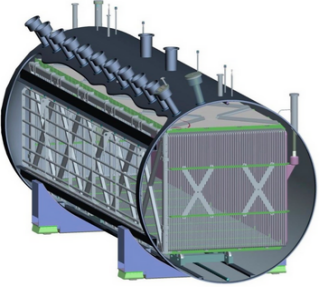

Noise Filtering

A paper on limiting detector noise in MicroBooNE has been published in JINST!

JINST 12, P08003 (2017): <http://iopscience.iop.org/article/10.1088/1748-0221/12/08/P08003>
(August 4th, 2017)

**Before
Noise
Removal**



**After
Noise
Removal**

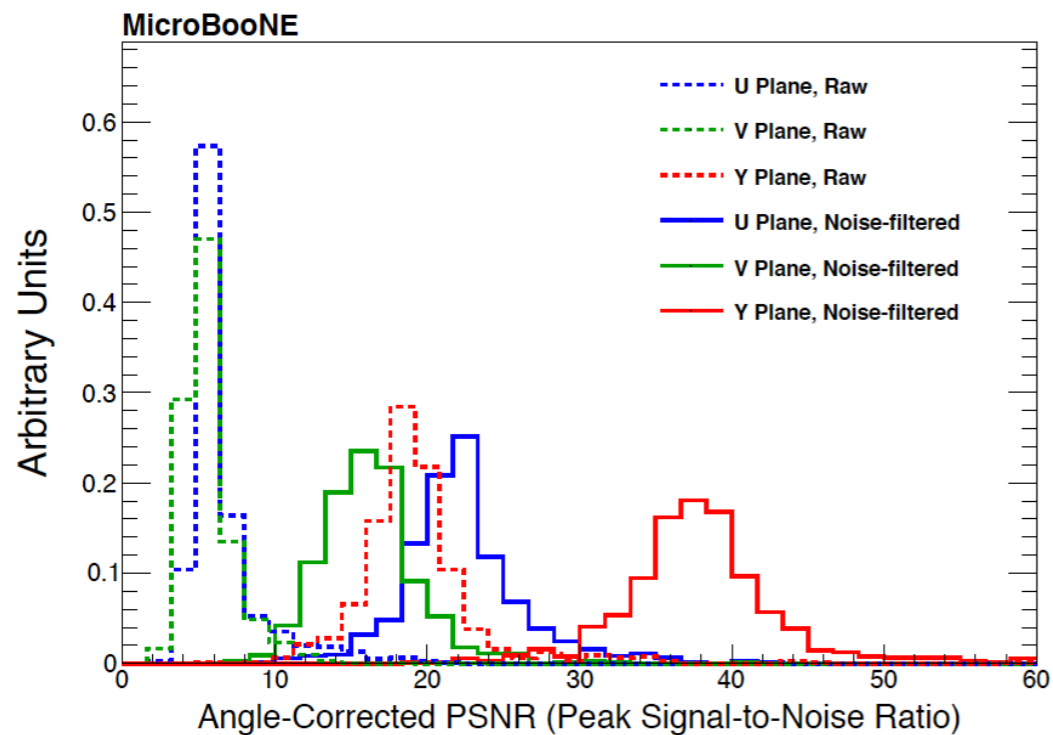
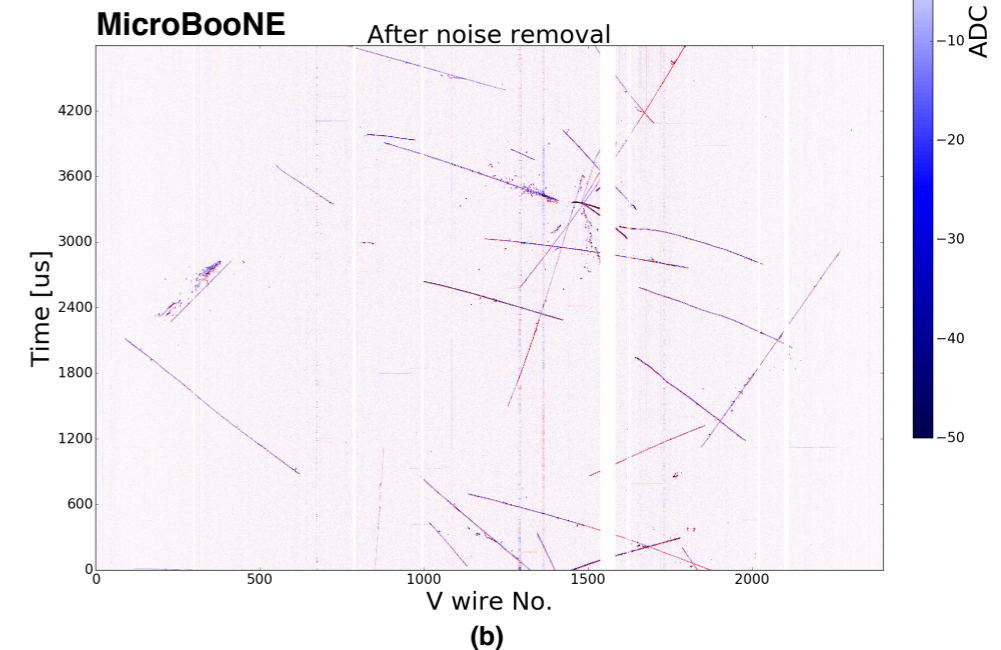

Signal-To-Noise Ratio Before And After Noise Mitigation Using Offline Software Technique.

Christopher Barnes, CIPANP 2018, May 30th, 2018

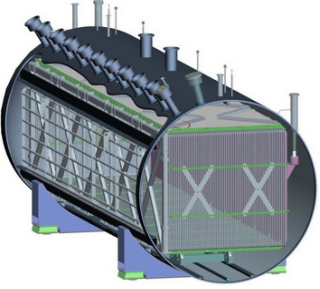

Signal Processing I.

First signal processing paper has been accepted for publication by JINST!

arXiv:1804.02583: <https://arxiv.org/pdf/1802.08709.pdf>
(April 9th, 2018)

This paper:

- describes field & electronics response simulation.
- presents a process for identifying the region of interest (ROI) a signal may be located within.

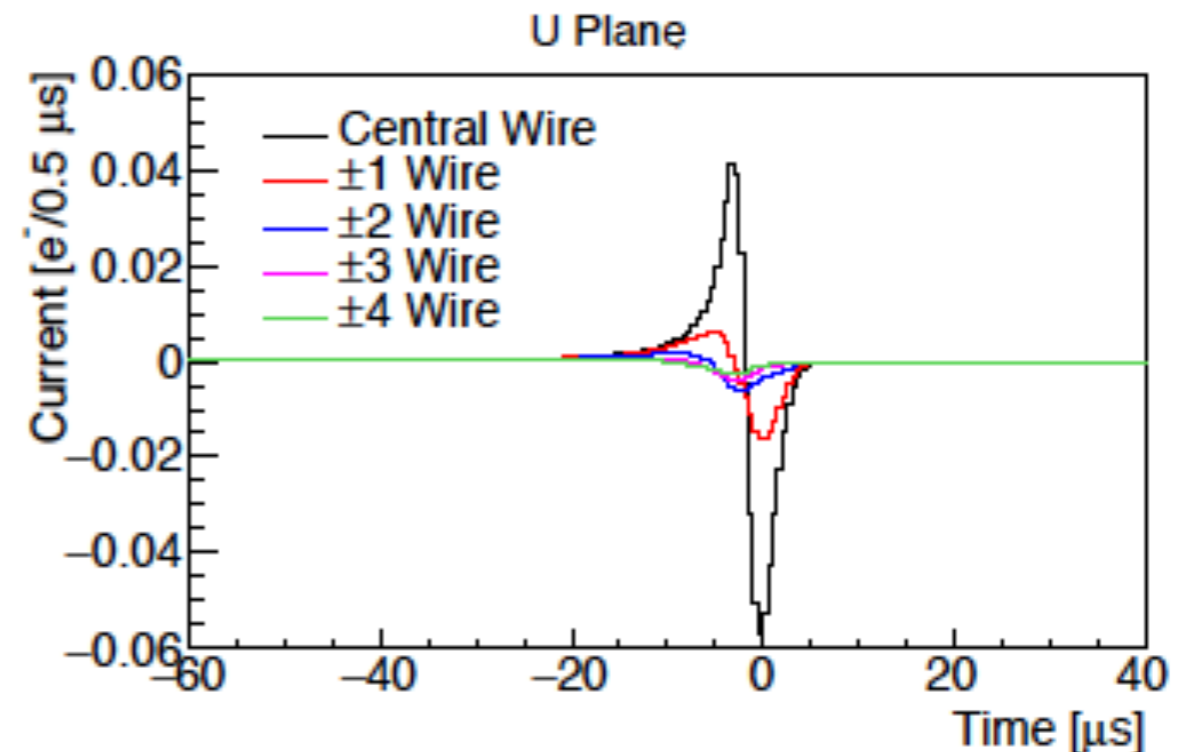
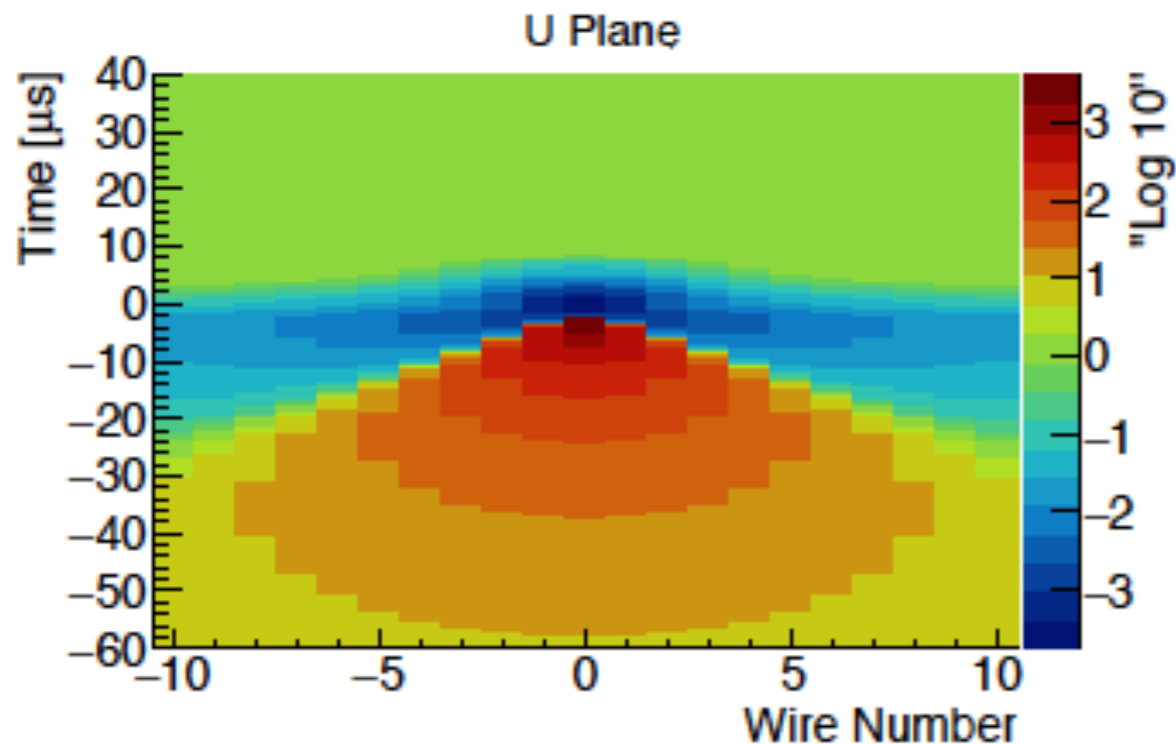

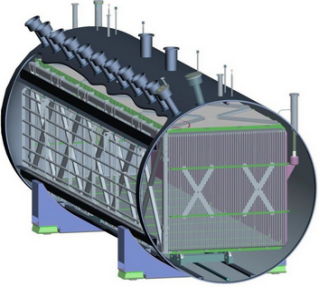

Signal Processing II.

Second signal processing paper has been accepted for publication by JINST!

arXiv:1802.08709: <https://arxiv.org/abs/1804.02583>
(April 10th, 2018)

Effects of Data-Driven Signal Processing

Charge Matching Across Wire Planes

These results are pioneering for the LArTPC community!

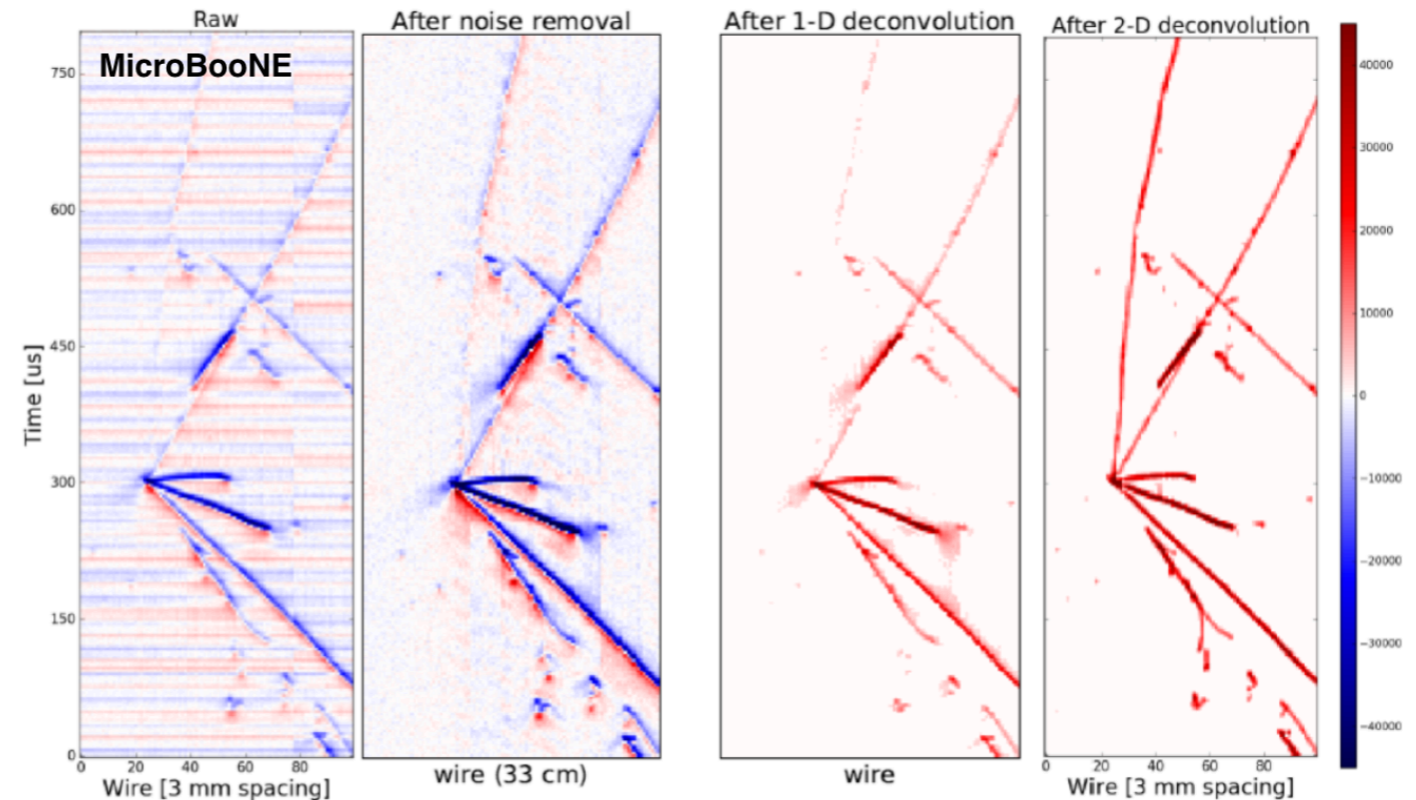

1D deconvolution, $30^\circ < \theta_{xz} < 50^\circ$

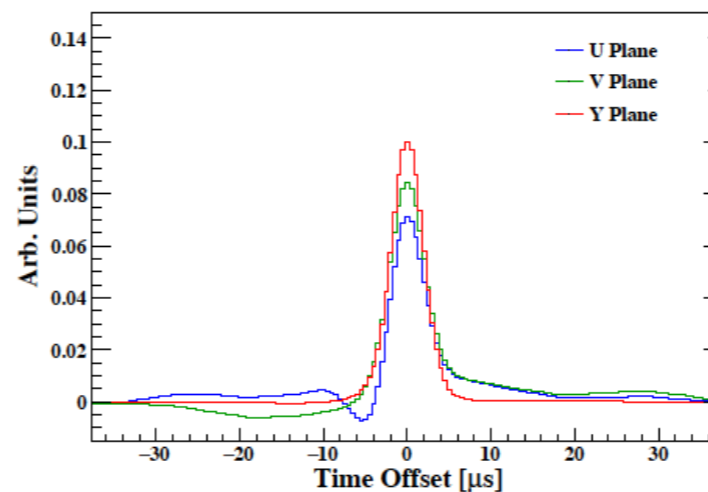

2D deconvolution, $30^\circ < \theta_{xz} < 50^\circ$

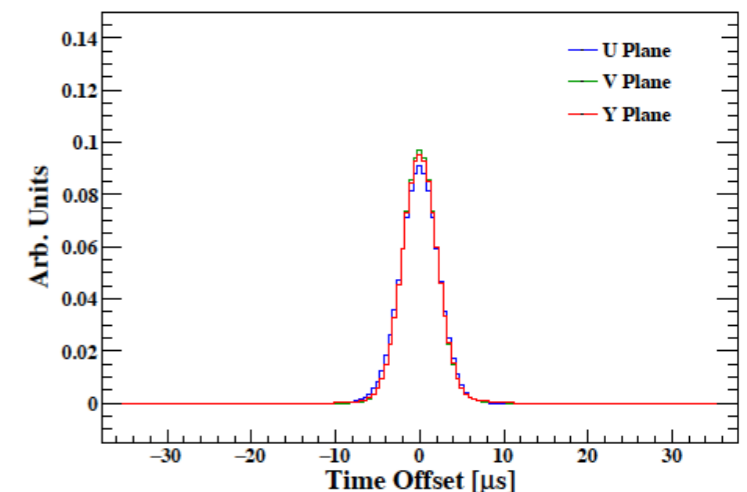

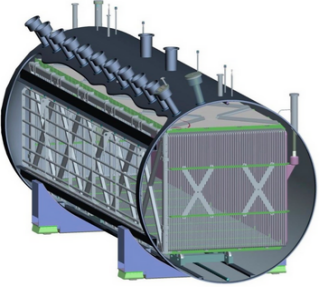

Space Charge Effects (SCE)

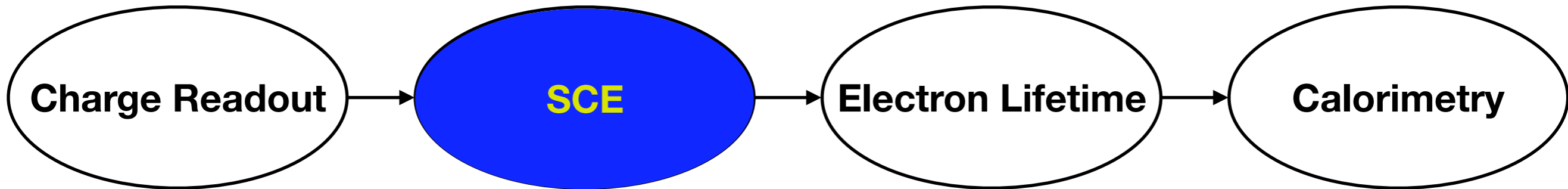

Space charge effects are the buildup of positive ions in the TPC active volume, distorting the electric field.

MuCS-tagged tracks

This worsens track reconstruction as a result.

Twofold Result of Space Charge Effects

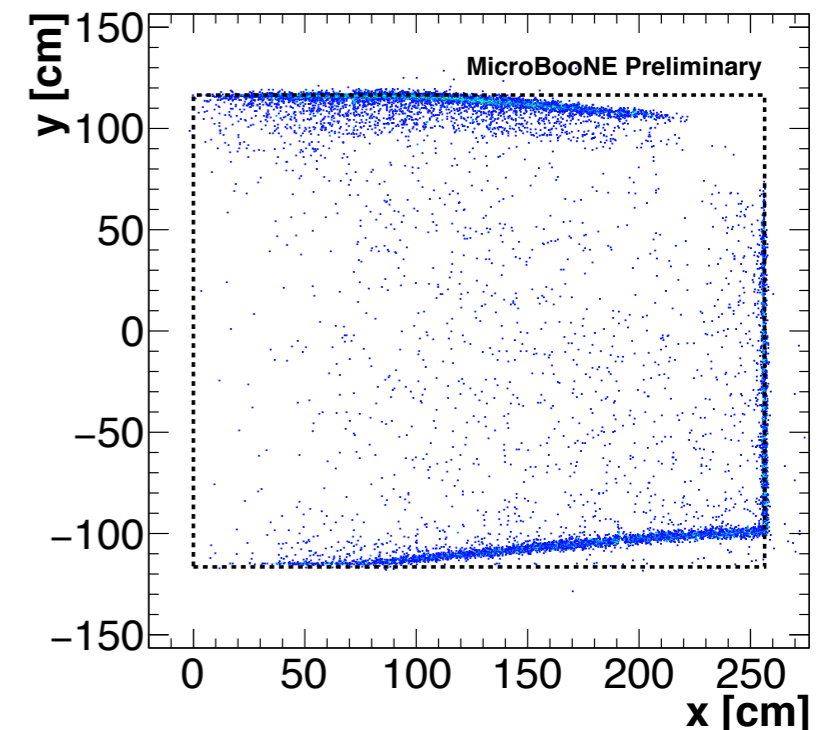
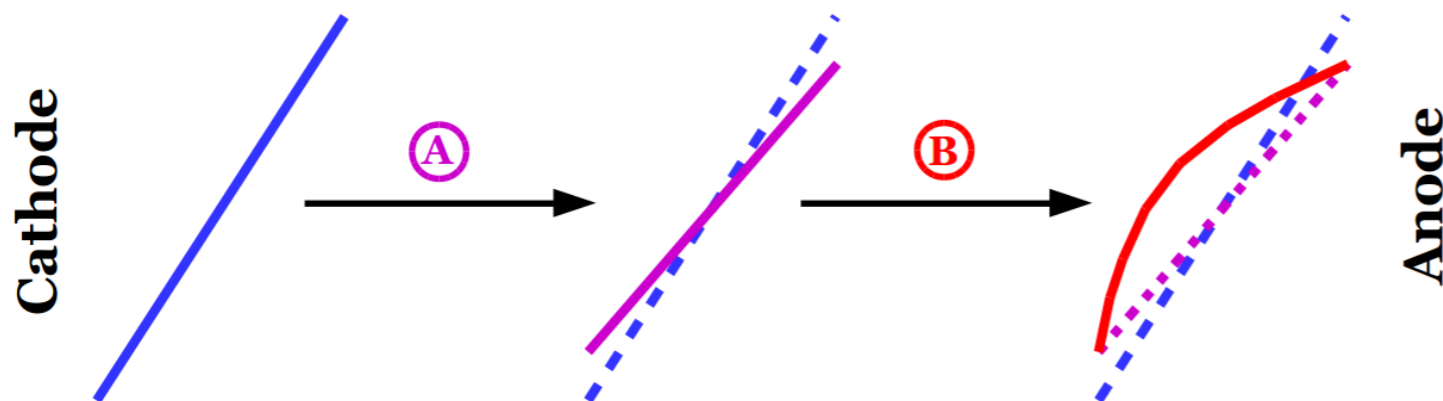

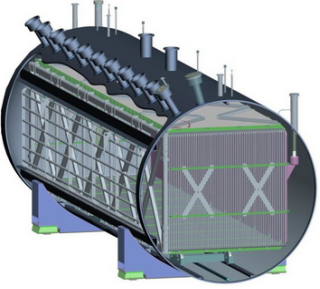

Simulation of Space Charge Effects

Effects on track reconstruction from space charge effects were integrated into our last simulation campaign (Early 2017).

Note the different color scales of the plots!

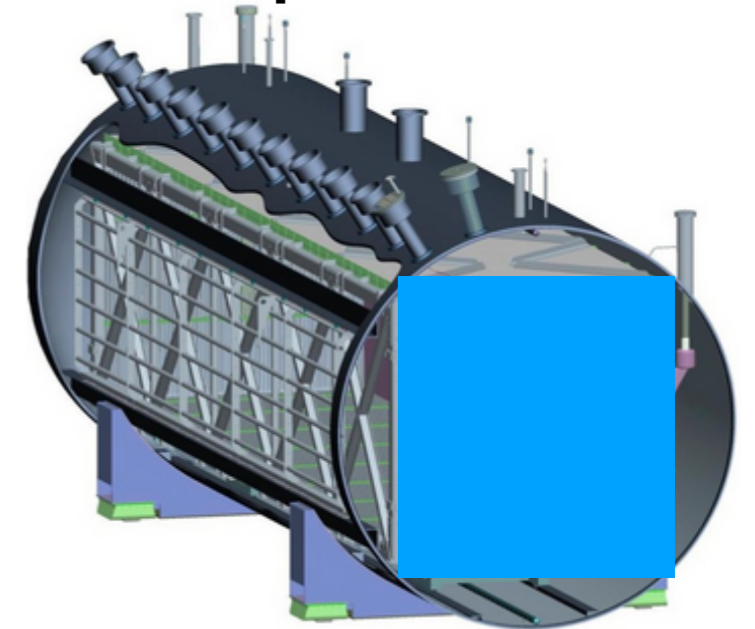
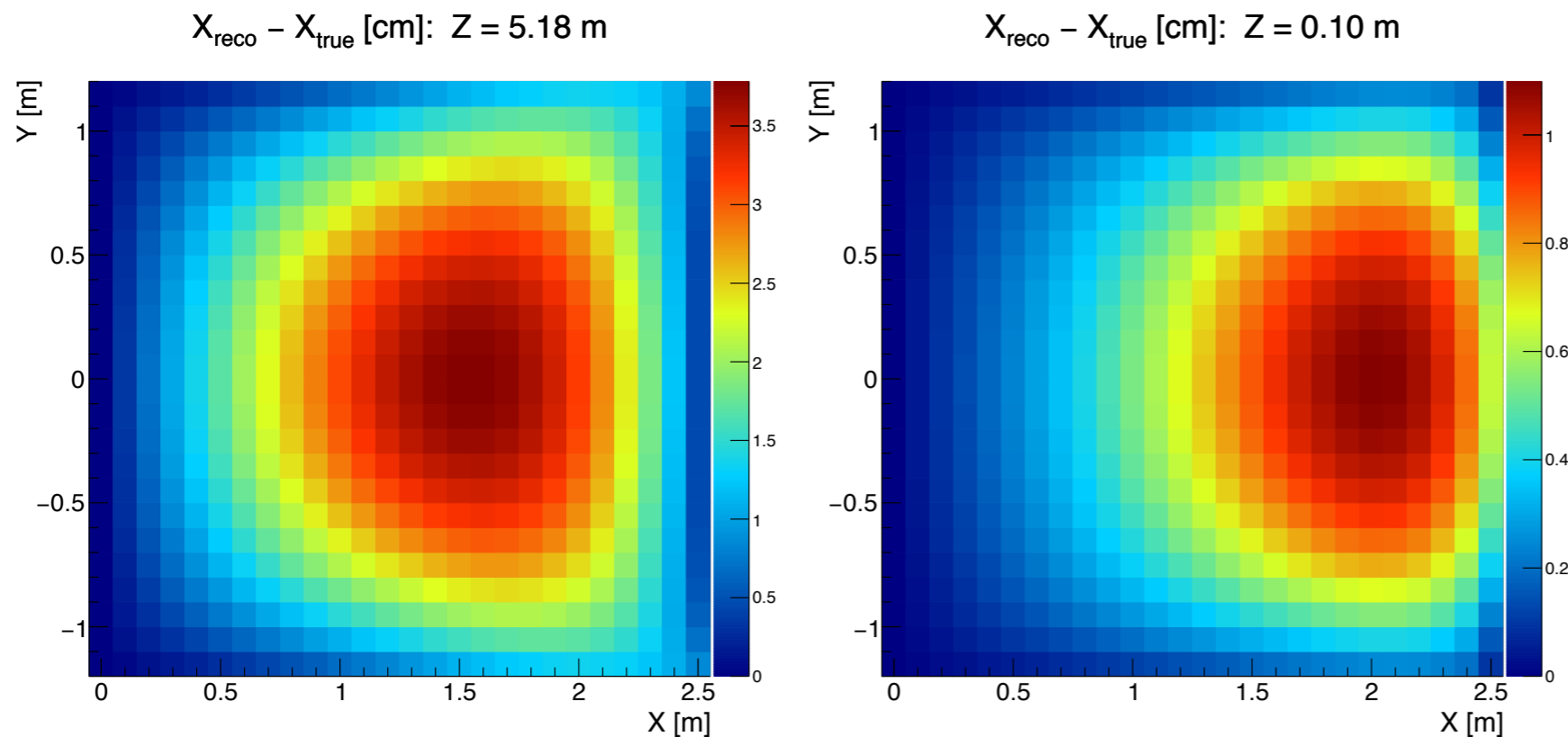

MicroBooNE Public Note #18: <http://microboone.fnal.gov/wp-content/uploads/MICROBOONE-NOTE-1018-PUB.pdf>

(November 29th, 2016)

Christopher Barnes, CIPANP 2018, May 30th, 2018

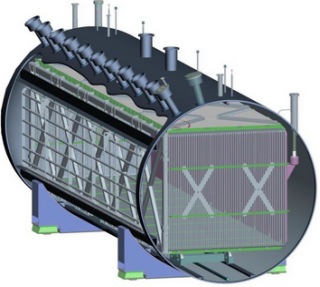

Space Charge Effect Calibration

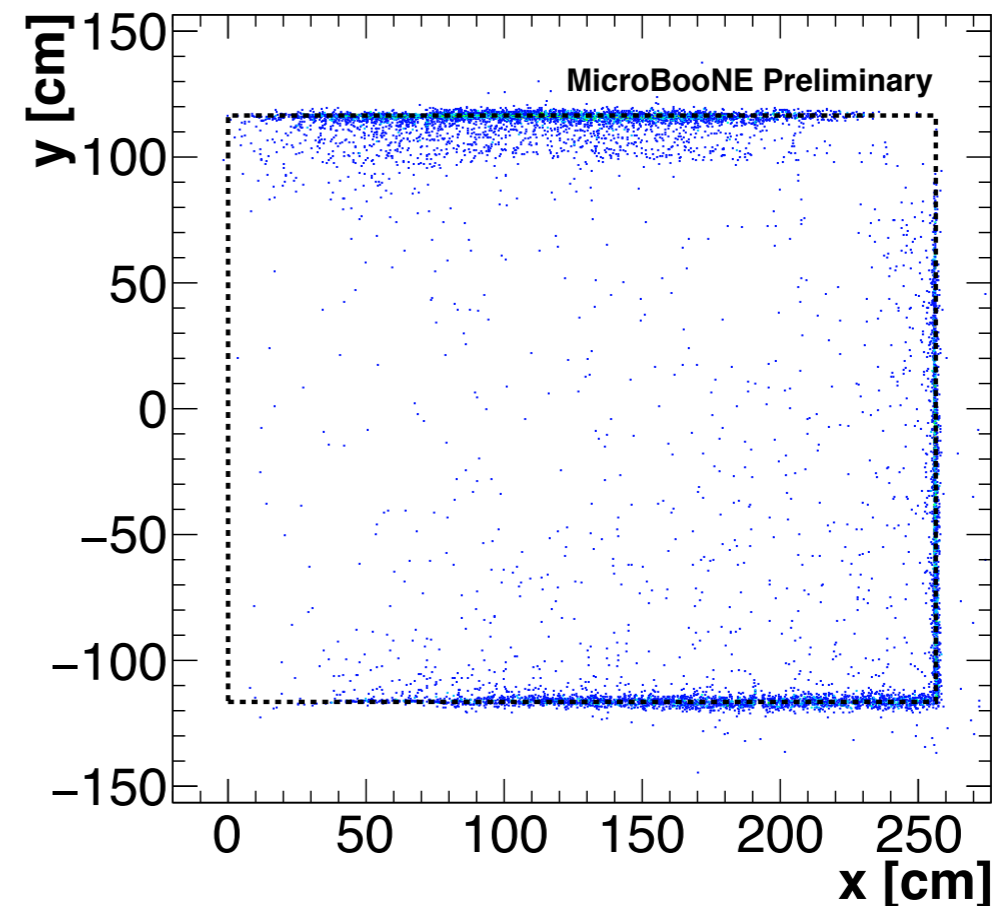
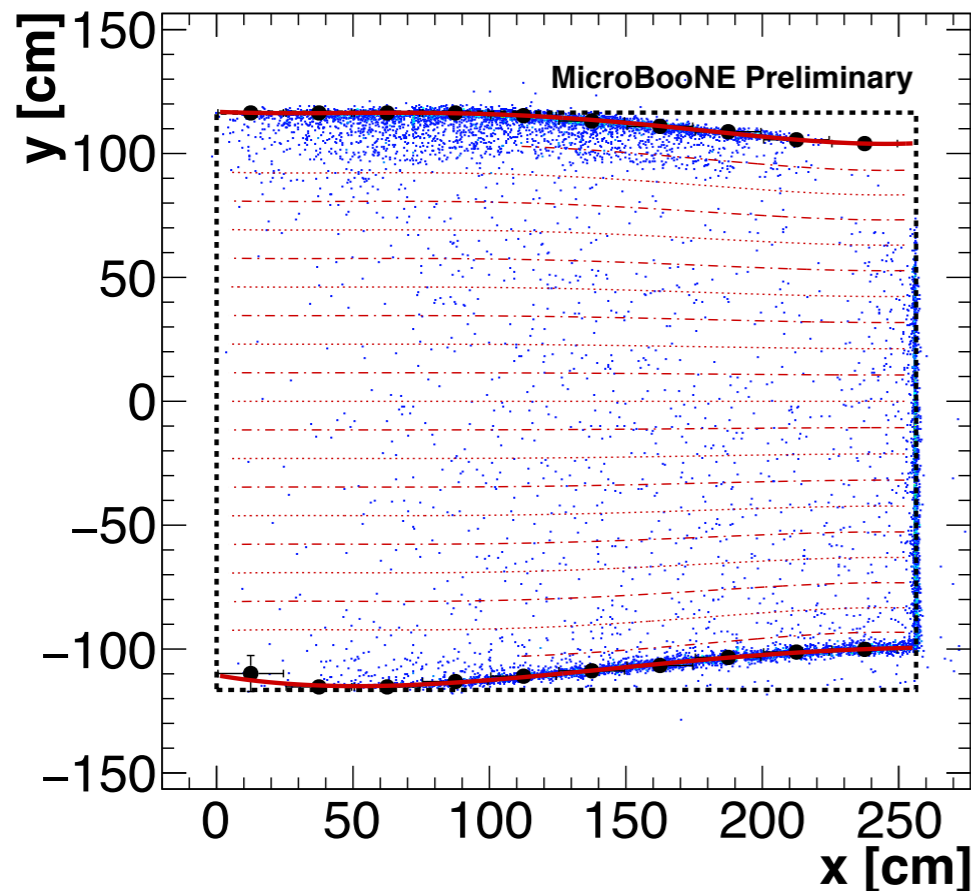

A data-driven correction for the MuCS-tagged tracks was demonstrated in Public Note #18.

A full data-driven calibration is underway, both for simulation and data.

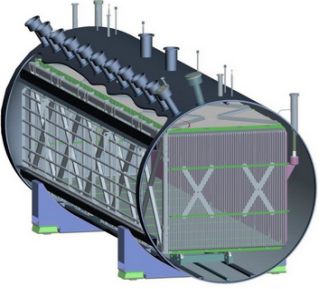

Electron Lifetime Measurement

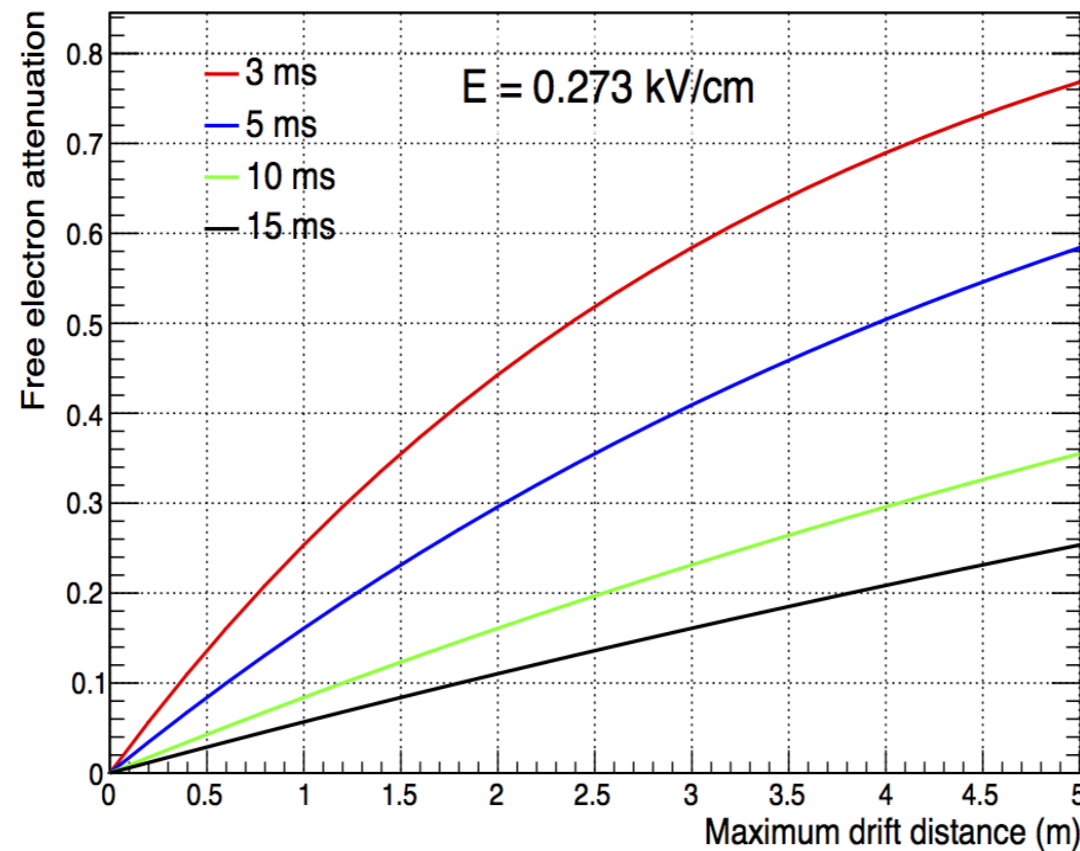
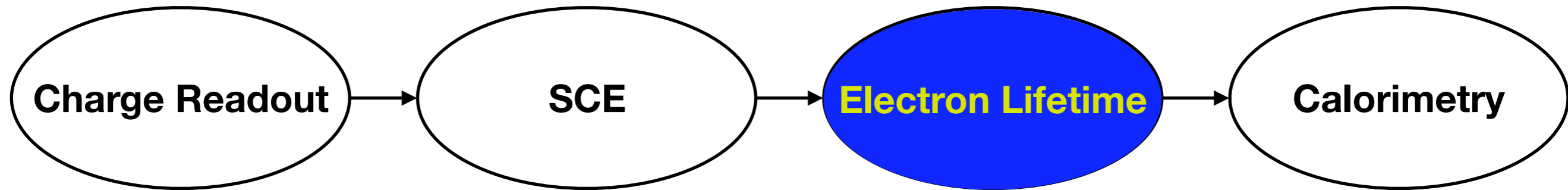

The concentration of water and oxygen in MicroBooNE affect the electron lifetime in the detector.

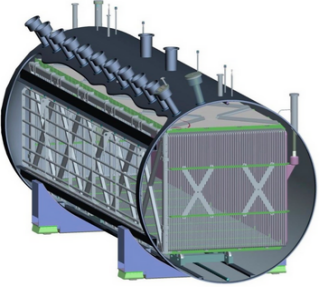

Electron Lifetime Measurement

MicroBooNE has demonstrated excellent liquid argon purity:

**Stable Purity Period:
Electron Lifetime = 18 ms**

Minimum Electron Lifetime = 6.8 ms

TPC Drift Time = 2.3 ms

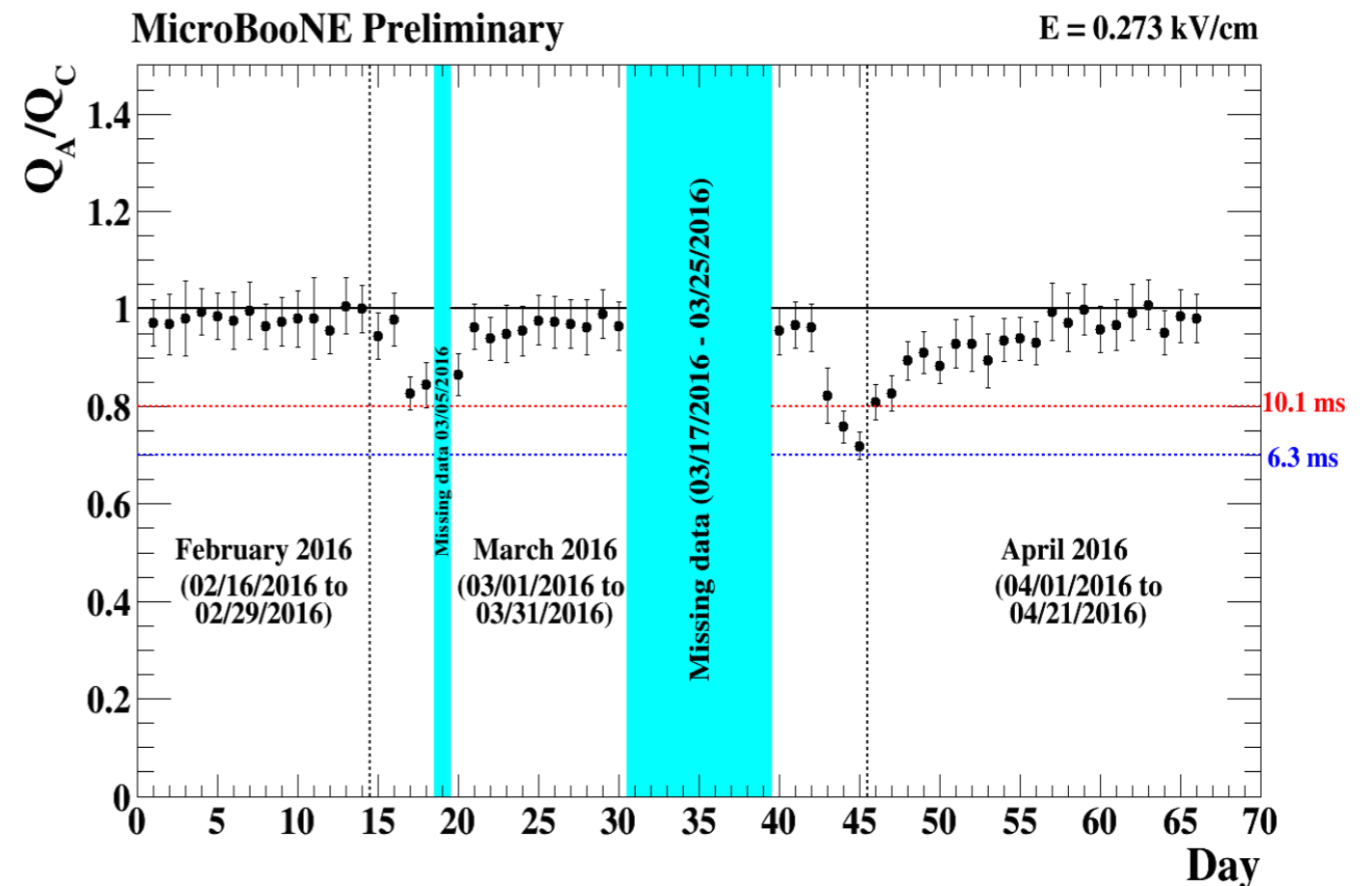

MicroBooNE Public Note # 26: <http://microboone.fnal.gov/wp-content/uploads/MICROBOONE-NOTE-1026-PUB.pdf>
(August 30th, 2017)

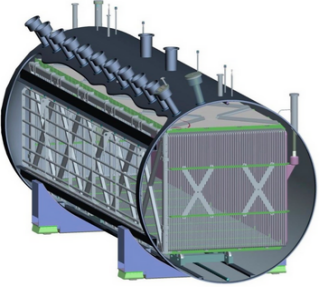

Calorimetry

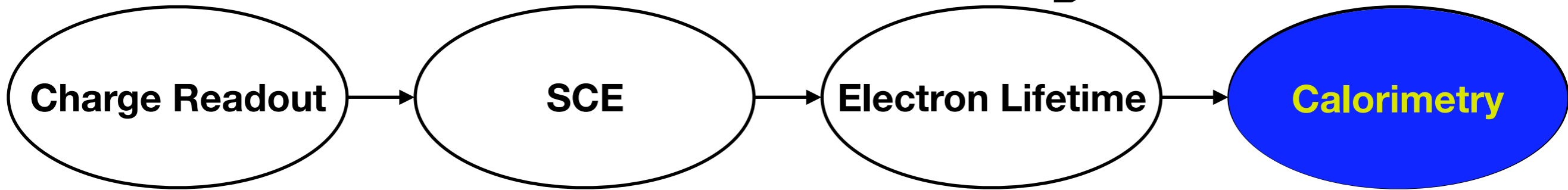

Plane 2

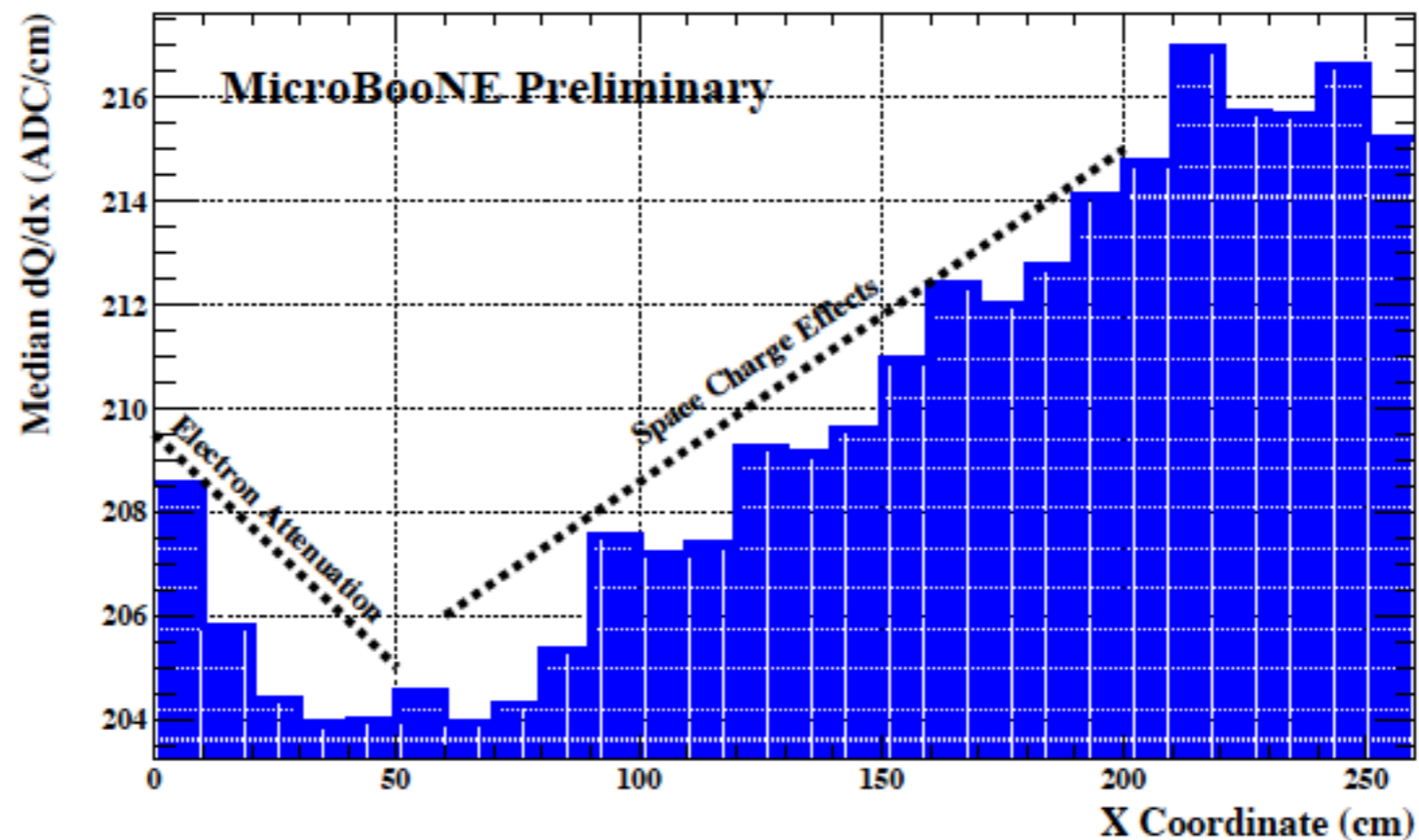

We have to perform a calibration on the LArTPC energy reconstruction to account for convolved detector effects.

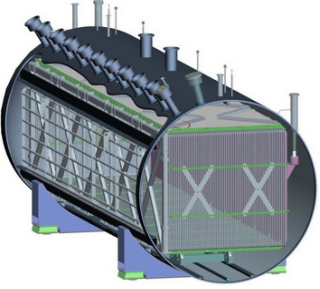

Calorimetry Calibration

dE/dx Calibration Results From ArgoNeuT

MicroBooNE is releasing results with a data-driven calibration for uniform energy-deposition in the LArTPC imminently.

Effective dE/dx is critical for a LArTPC experiment to achieve its physics goals.

This calibration is being utilized in results that MicroBooNE will share at conferences this summer.

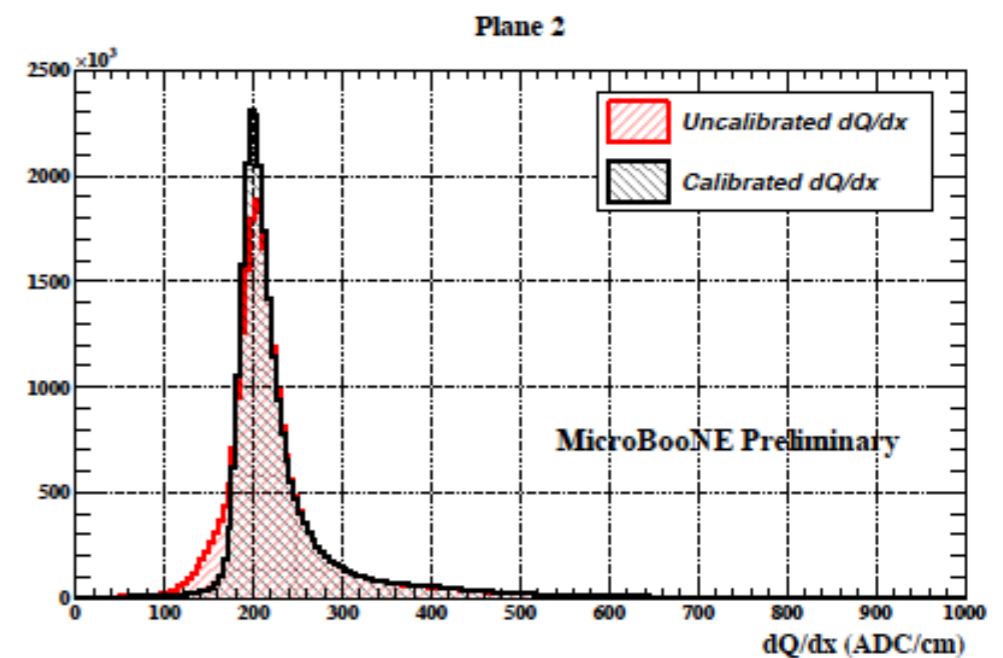
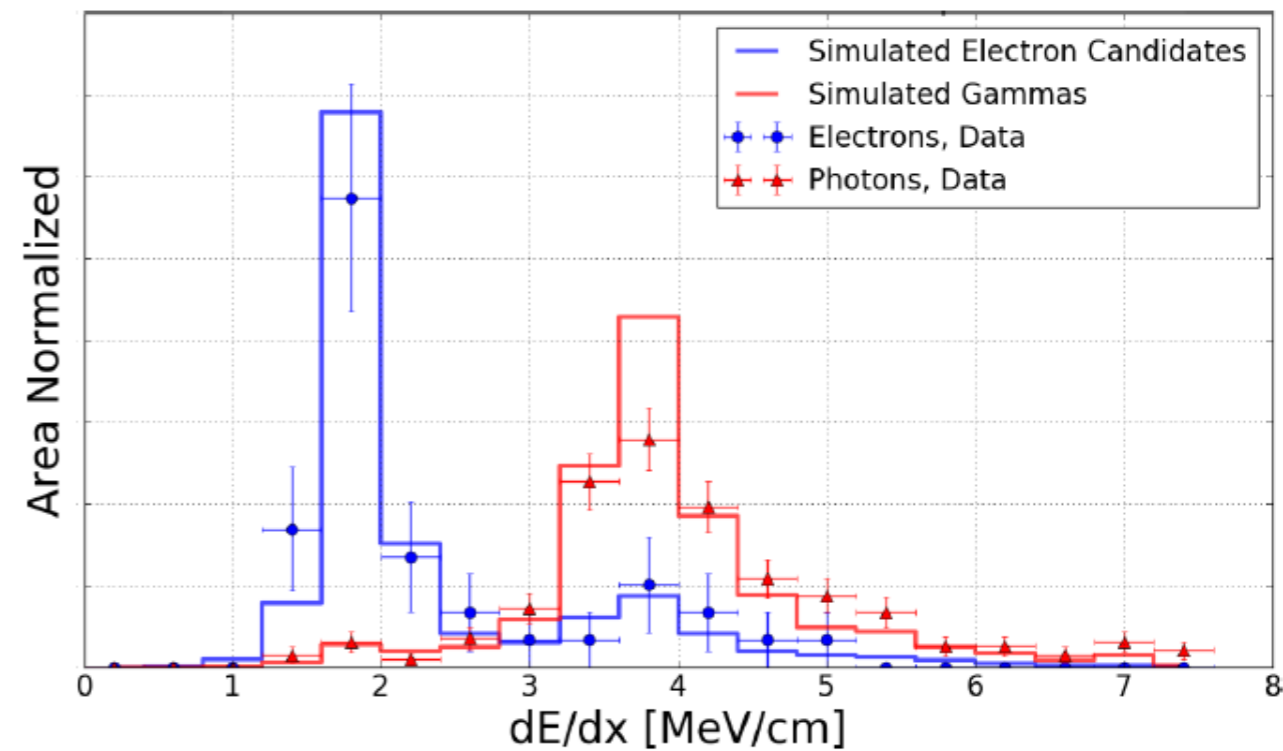

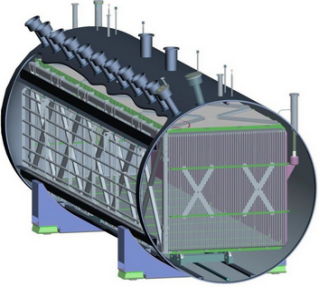

Calorimetry Calibration

This calibration proceeds in two steps:

1. dQ/dx Calibration

- Calibrate wire coordinate-dependent effects.
- Calibrate drift direction-dependent effects.
- Calibrate clock time-dependent effects.

2. dE/dx Calibration

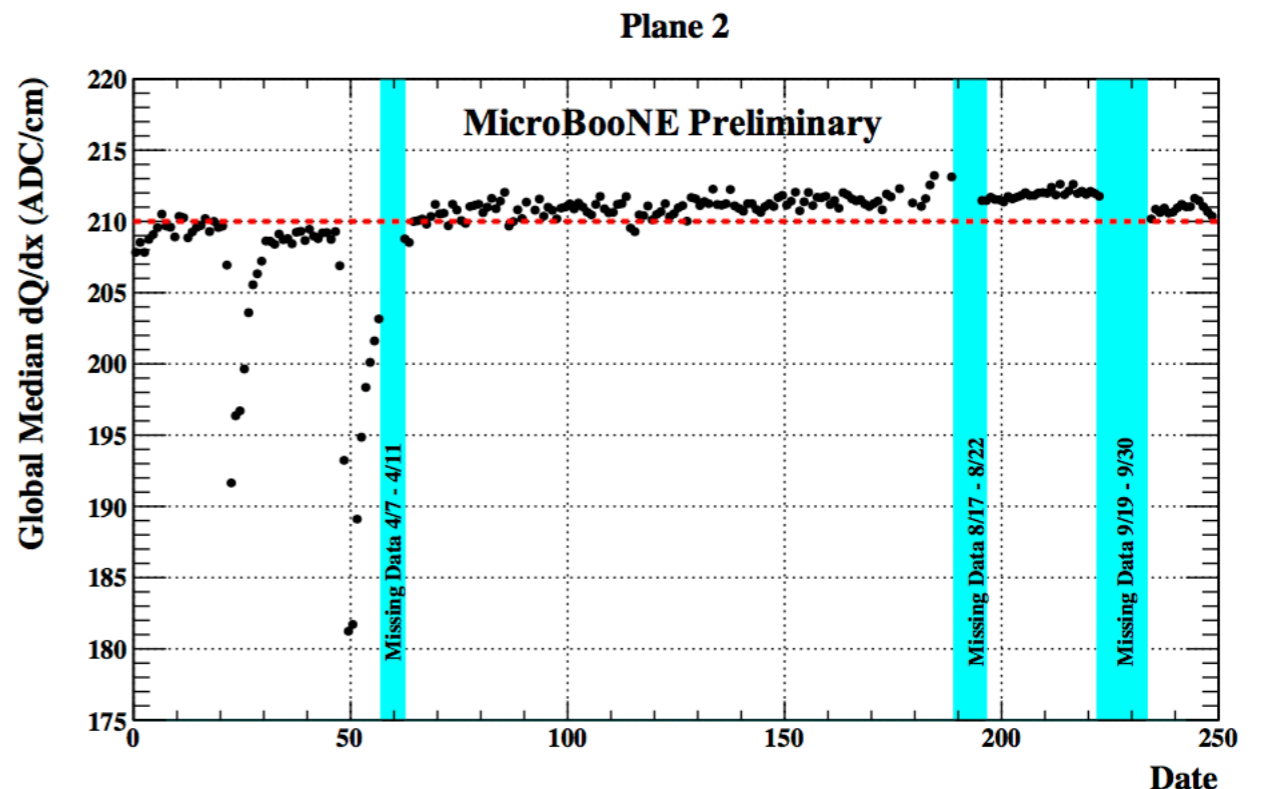
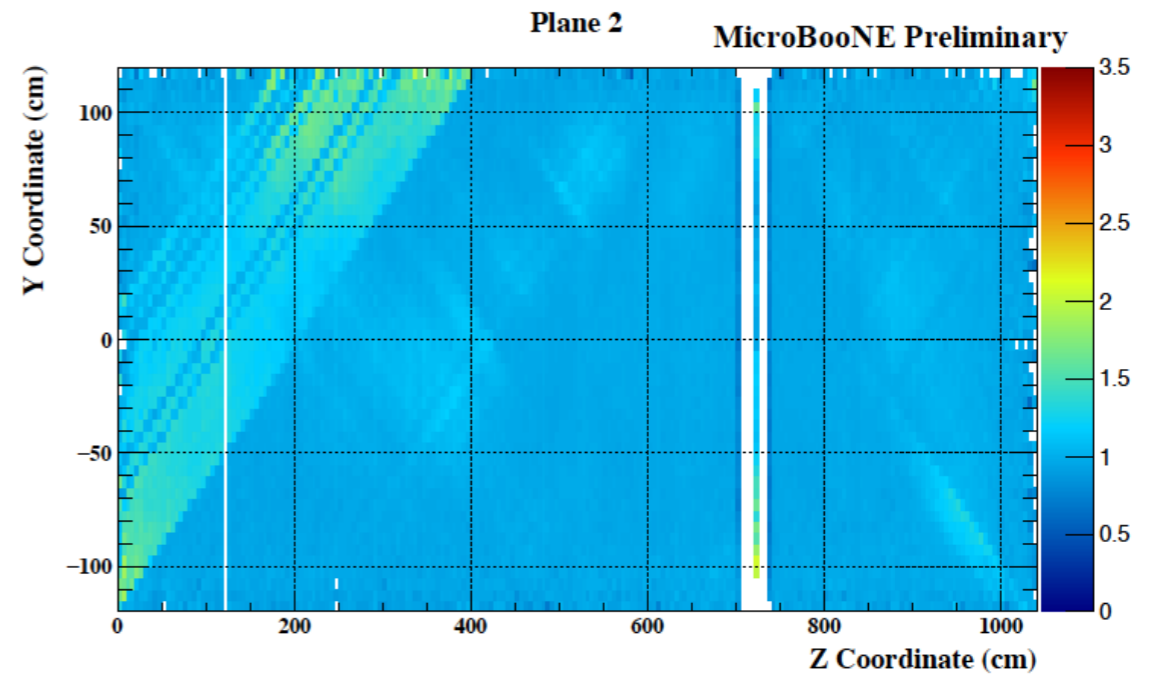

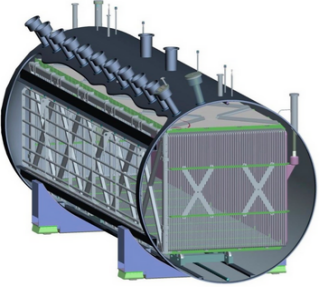

Summary

- MicroBooNE's liquid argon is very pure.
- The noise filtering/signal processing calibrations are complete.
- A full SCE calibration is coming soon.
- We are simultaneously working to calibrate fundamental detector effects.
- Publications of MicroBooNE calibrations inform future LArTPC experiments (protoDUNE, ICARUS, SBND, DUNE).
- Thank you!

Backup

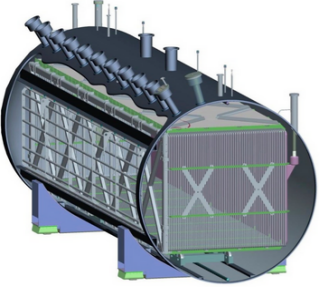

Anode-Piercing/ Cathode-Piercing Tracks

Anode-Piercing Tracks in Off-Beam Cosmic Events: Track-Hit Density Per Event

Cathode-Piercing Tracks in Off-Beam Cosmic Events: Track-Hit Density Per Event

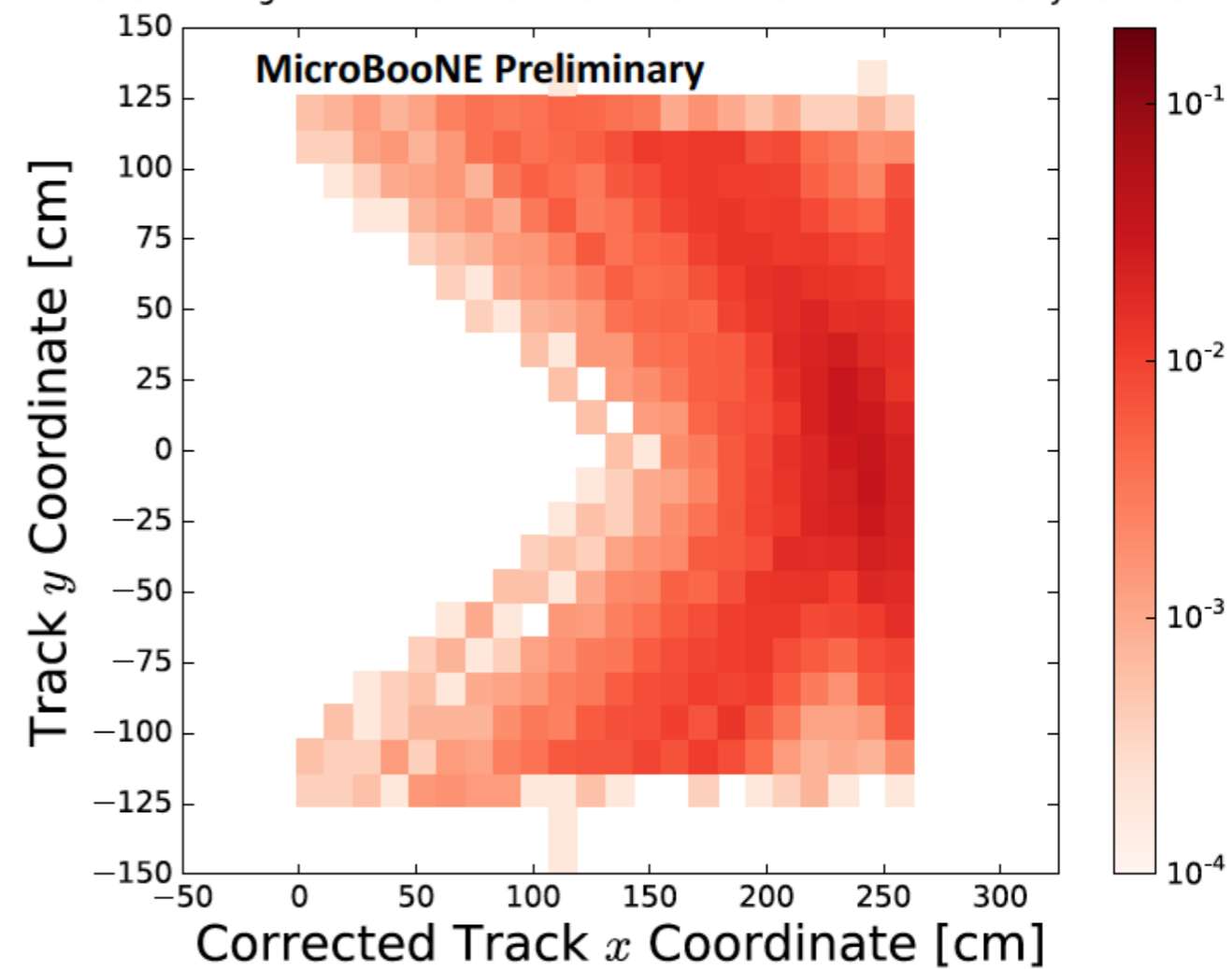
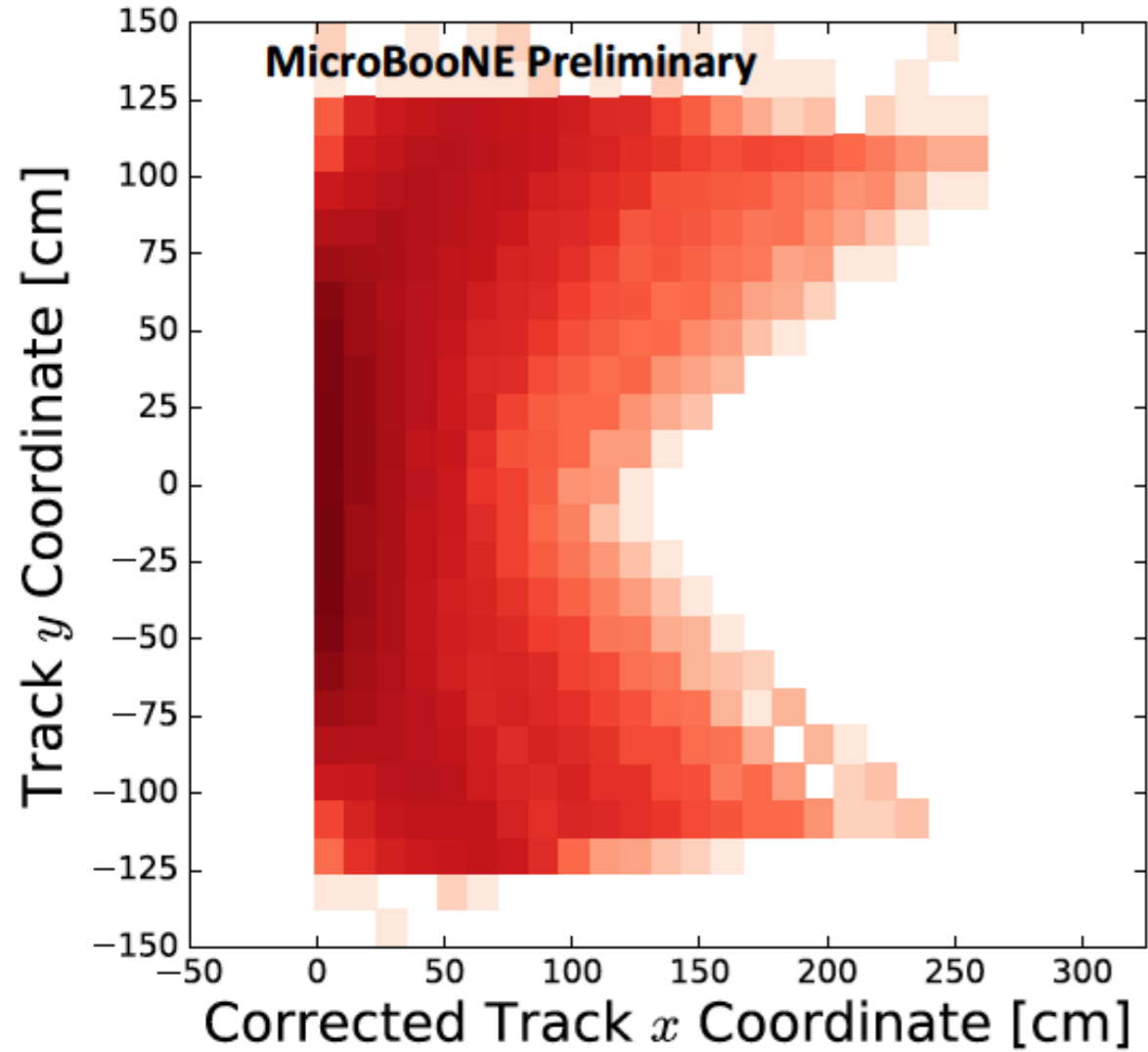

The coverages of anode-piercing and cathode-piercing tracks are biased because they must pierce that respective side of the TPC.

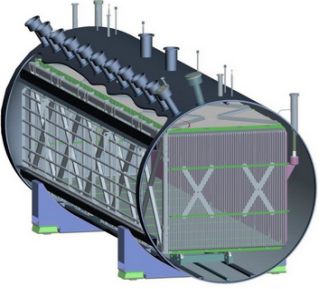

Anode-Cathode Crossing Tracks

\mathcal{X} -projected length of cosmic ray muon tracks.

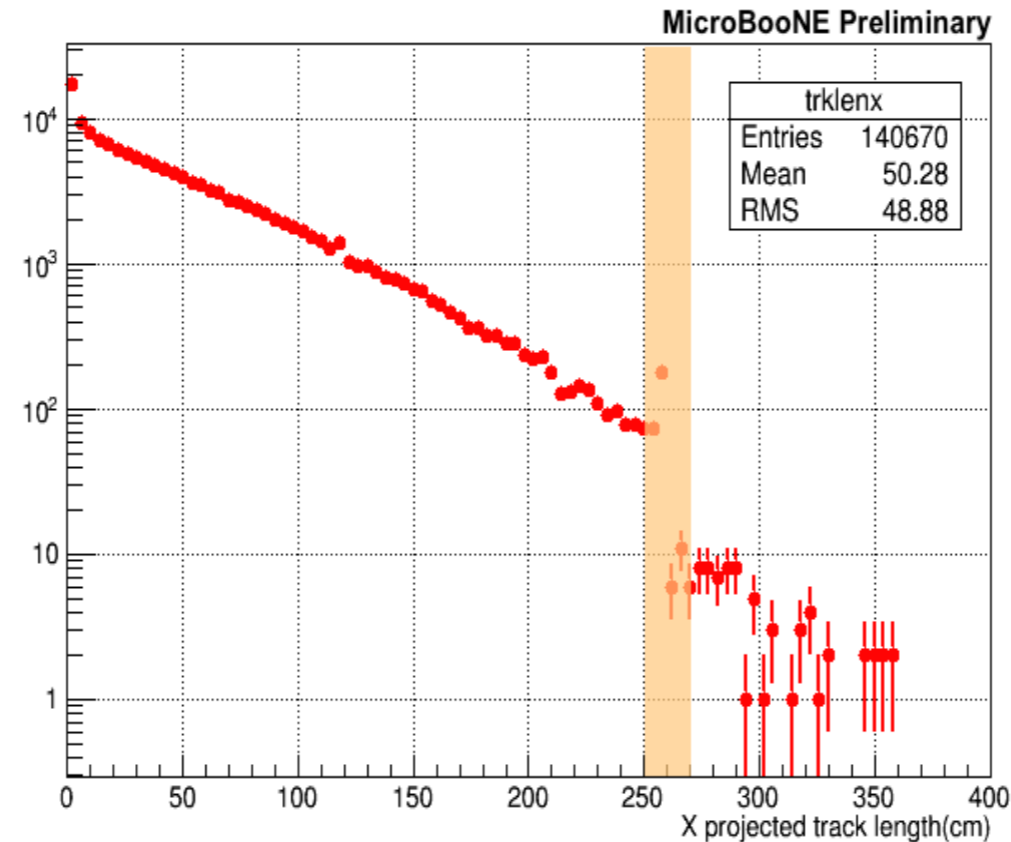

Anode-cathode crossing tracks are selected according to their \mathcal{X} -projected length.

This distribution has contingency ([250 cm, 270 cm]) to account for reconstruction effects.

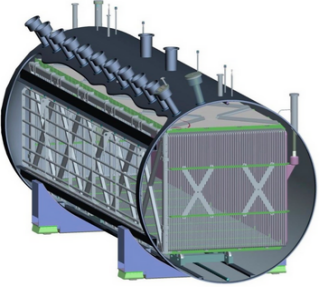

“Log 10” Scale

i = electrons per $0.5 \mu\text{s}$

$$i \text{ in "Log 10"} = \begin{cases} \log_{10}(i \cdot 10^5), & \text{if } i > 1 \times 10^{-5}, \\ 0, & \text{if } -1 \times 10^{-5} \leq i \leq 1 \times 10^{-5}, \\ -\log_{10}(-1 \cdot i \cdot 10^5) & \text{if } i < -1 \times 10^{-5}. \end{cases}$$

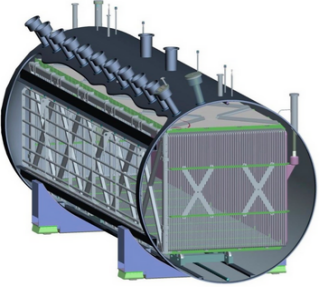

ROI Finding

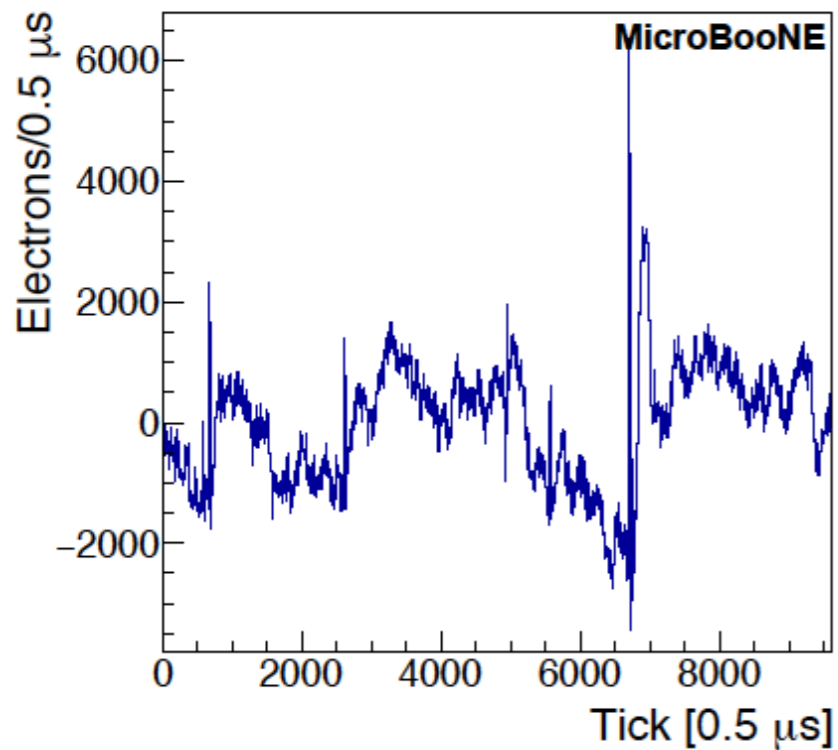

No low-frequency filter

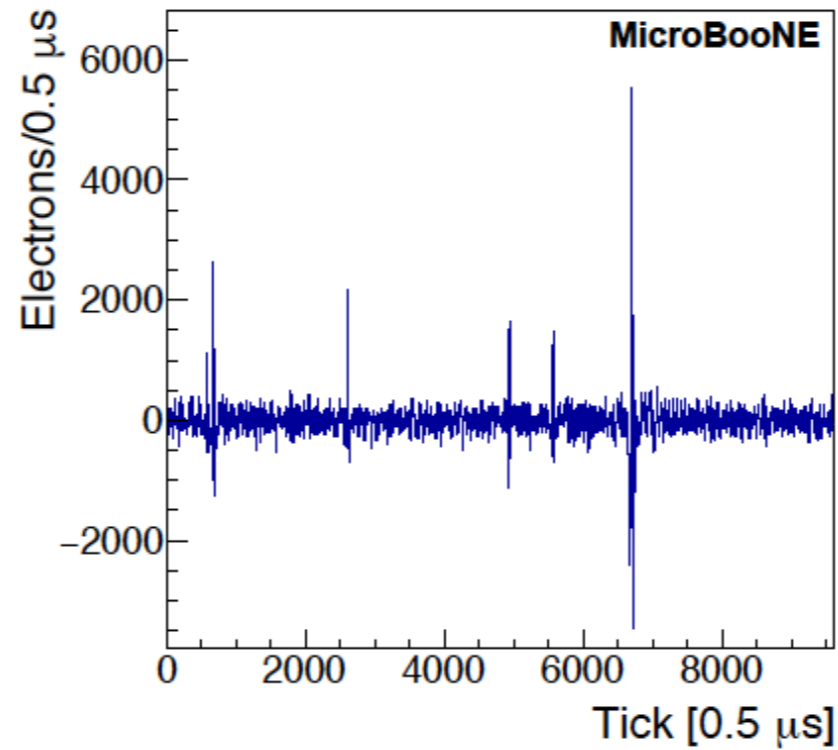

Tight low-frequency filter

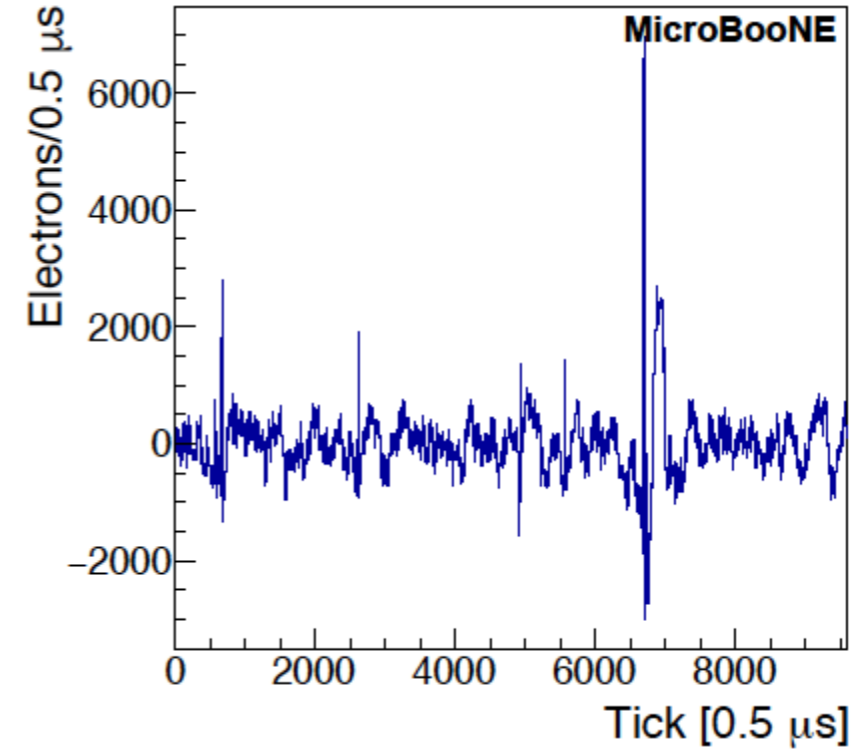

Loose low-frequency filter

Two filters intended to remove low-frequency components of the input signal are used to find the signal Regions of Interest (ROIs). They are used on the induction planes only.

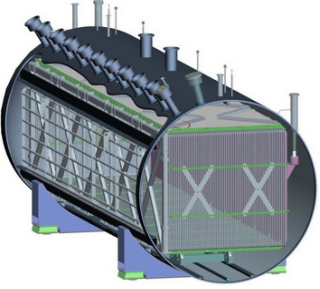

2D Deconvolution

$$\begin{pmatrix} M_1(\omega) \\ M_2(\omega) \\ \vdots \\ M_{n-1}(\omega) \\ M_n(\omega) \end{pmatrix} = \begin{pmatrix} R_0(\omega) & R_1(\omega) & \dots & R_{n-2}(\omega) & R_{n-1}(\omega) \\ R_1(\omega) & R_0(\omega) & \dots & R_{n-3}(\omega) & R_{n-2}(\omega) \\ \vdots & \vdots & \ddots & \vdots & \vdots \\ R_{n-2}(\omega) & R_{n-3}(\omega) & \dots & R_0(\omega) & R_1(\omega) \\ R_{n-1}(\omega) & R_{n-2}(\omega) & \dots & R_1(\omega) & R_0(\omega) \end{pmatrix} \cdot \begin{pmatrix} S_1(\omega) \\ S_2(\omega) \\ \vdots \\ S_{n-1}(\omega) \\ S_n(\omega) \end{pmatrix}$$

In our signal processing, we now use a 2D filter, in time and in the wire coordinate.

Previously, only 1D convolution in time was used.

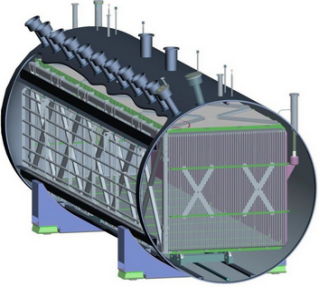

Data-Driven MuCS Correction

$$y_{\text{corr}} = y_{\text{reco}} - \Delta y(x_{\text{reco}}, y_{\text{reco}})$$

$$\Delta y(x_{\text{reco}}, y_{\text{true}}) = \begin{cases} (f_{\text{top}}(x_{\text{reco}}) - y_{\text{top}}) g(y_{\text{true}}), & \text{if } y_{\text{reco}} > 0 \\ (f_{\text{bottom}}(x_{\text{reco}}) - y_{\text{bottom}}) g(y_{\text{true}}), & \text{if } y_{\text{reco}} < 0 \end{cases}$$

$f_{\text{top}}(x_{\text{reco}})$ ($f_{\text{bottom}}(x_{\text{reco}})$): a quartic polynomial that gives the correction that must be applied as a function of \mathcal{X} .

$g(y_{\text{true}})$: is a scaling function that describes the change in the correction with y .

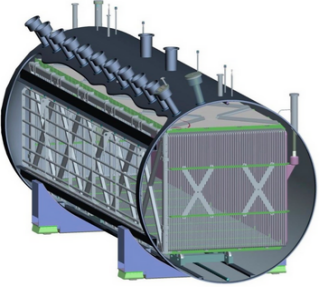

dE/dx Calculation

We calculated dE/dx from dQ/dx by using the following formula:

$$\left(\frac{dE}{dx}\right)_{calibrated} = \frac{\exp\left(\frac{\left(\frac{dQ}{dx}\right)_{calibrated}}{C} \cdot \frac{\beta_p W_{ion}}{\rho \epsilon}\right) - \alpha}{\frac{\beta_p}{\rho \epsilon}}$$

C – Calibration constant to convert ADC values to number of electrons

W_{ion} – 23.6×10^{-6} MeV/electron (work function of argon)

ϵ – 0.273 kV/cm (MicroBooNE drift electric field)

ρ – 1.38 g/cm^3 (liquid argon density at a pressure 18.0 psia)

β_p and α were determined by ArgoNeuT, which operated at a drift electric field of 0.481 kV/cm.