



U.S. MAGNET
DEVELOPMENT
PROGRAM

20 T Common Coil Design Iteration

Ramesh Gupta

6/14/2022

Previous Mechanical and Magnetic Designs for 20 T Common Coil (similar but not the same)

✓ **Acceptable stresses/strain on conductor, 15% margin, good field quality**

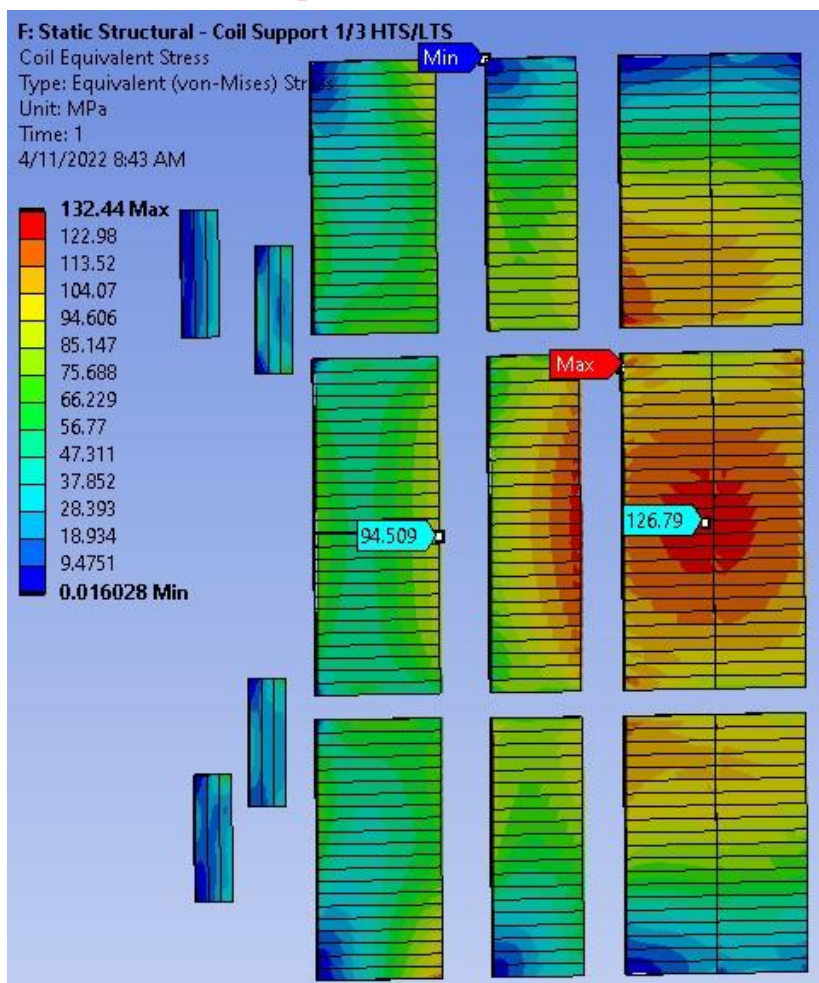

I(kA)	Bo (T)	Bpk(HTS)	Bpk(HTS)	Margins
13.57	20.00	20.654	13.503	15.0%
15.83	23.00	23.757	15.489	
15.83	23.00	23.757	15.489	
16.01	23.25	24.018	15.659	

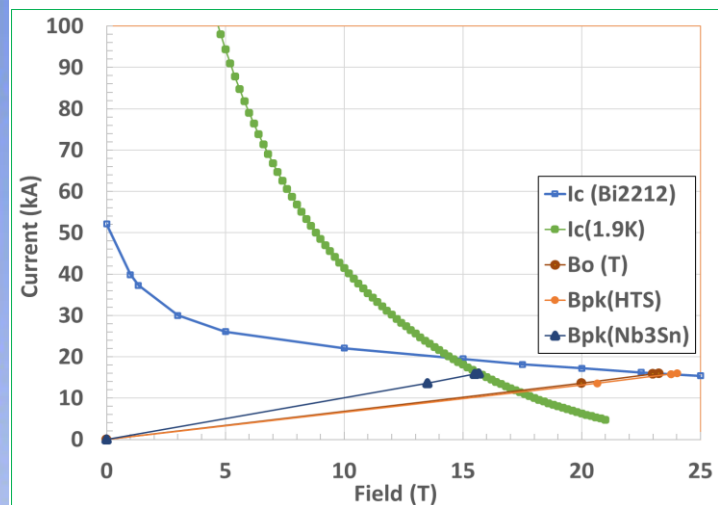

SKREW RELATIVE MULTIPOLES (1.D-4):

a 1:	0.00000	a 2:	-0.01890	a 3:	-0.00000
a 4:	0.00591	a 5:	-0.00000	a 6:	0.11424
a 7:	0.00000	a 8:	0.02483	a 9:	-0.00000
a10:	0.14186	a11:	0.00000	a12:	-0.00881
a13:	0.00000	a14:	0.00515	a15:	-0.00000
a16:	0.00259	a17:	0.00000	a18:	0.00066
a19:	-0.00000	a20:	0.00012	a	

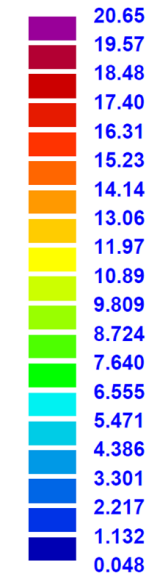

All LTS Layers: Identical

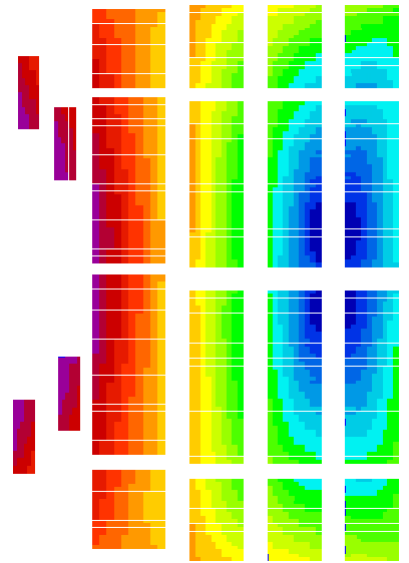

Next Step:

- Same Design
- Structure concept

NORMAL RELATIVE MULTIPOLES (1.D-4):

b 1:	10000.00000	b 2:	0.00000	b 3:	0.00537
b 4:	-0.00000	b 5:	0.02576	b 6:	0.00000
b 7:	-0.07742	b 8:	-0.00000	b 9:	-0.41532
b10:	0.00000	b11:	-0.26062	b12:	-0.00000
b13:	-0.00646	b14:	-0.00000	b15:	-0.00448
b16:	0.00000	b17:	-0.00436	b18:	0.00000
b19:	-0.00092	b20:	-0.00000	b	



Distribution of Stresses (@19 T)

Von Mises

Horizontal

Vertical

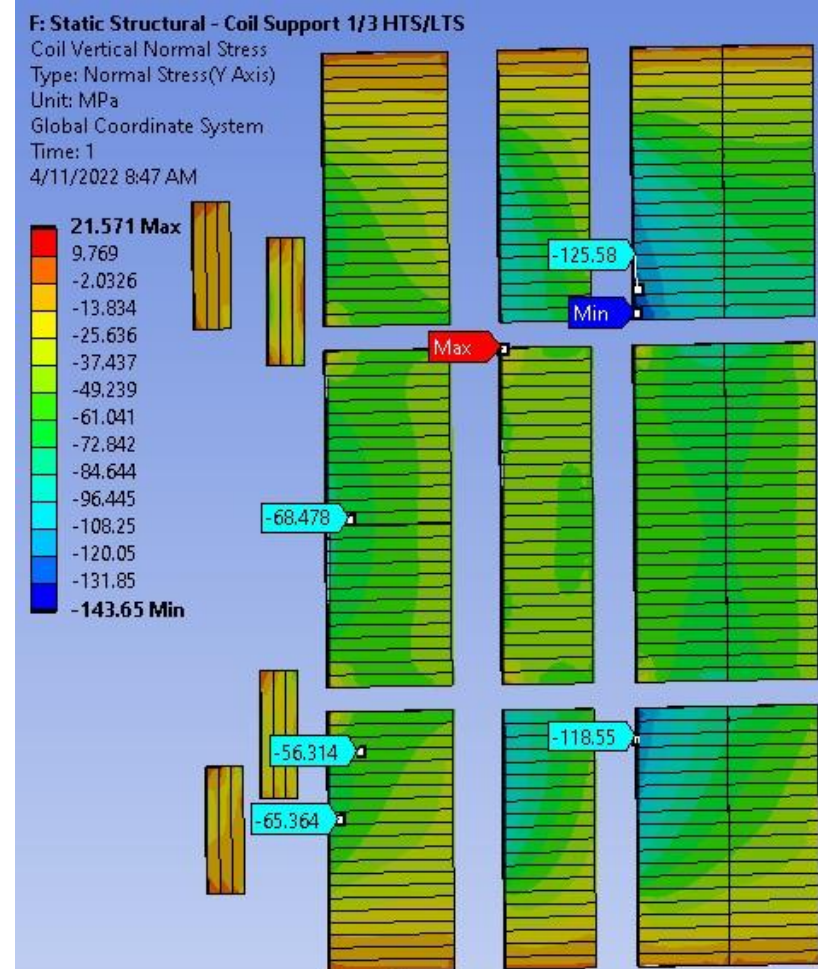
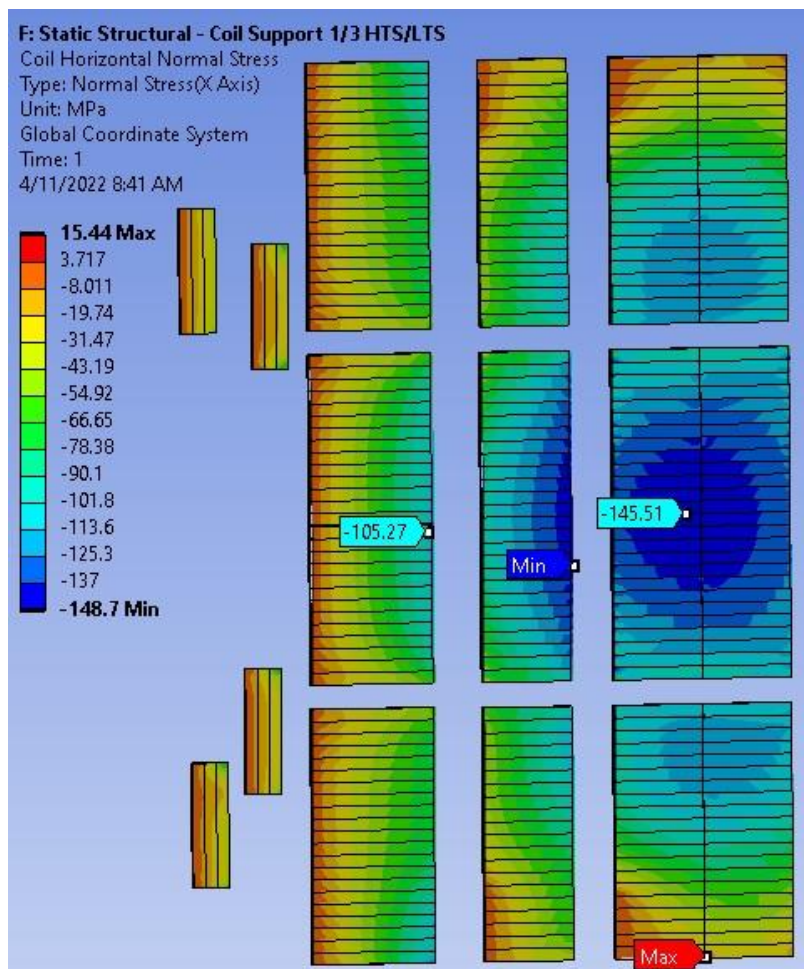
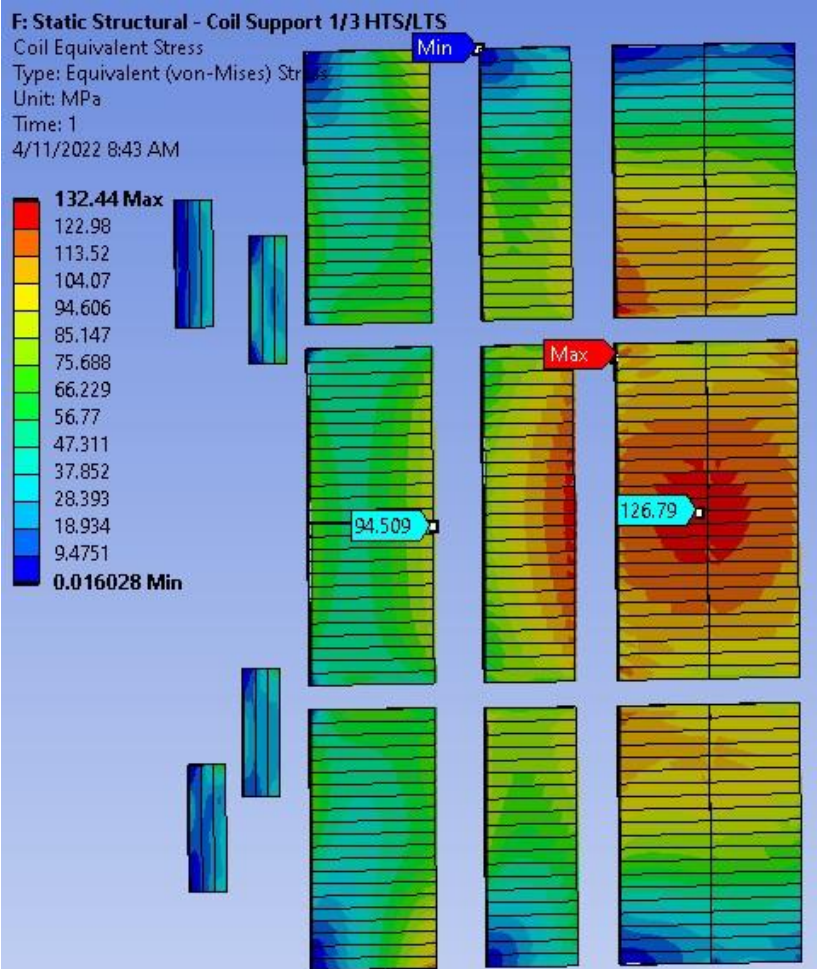



New 20 T HTS/LTS Hybrid Design (May 2022) (spacers in magnetic design takes input from mechanical)

Previous design analyzed with ANSYS

New Magnetic design optimized for margin and field quality

25 mm clear bore + > 3mm for structure

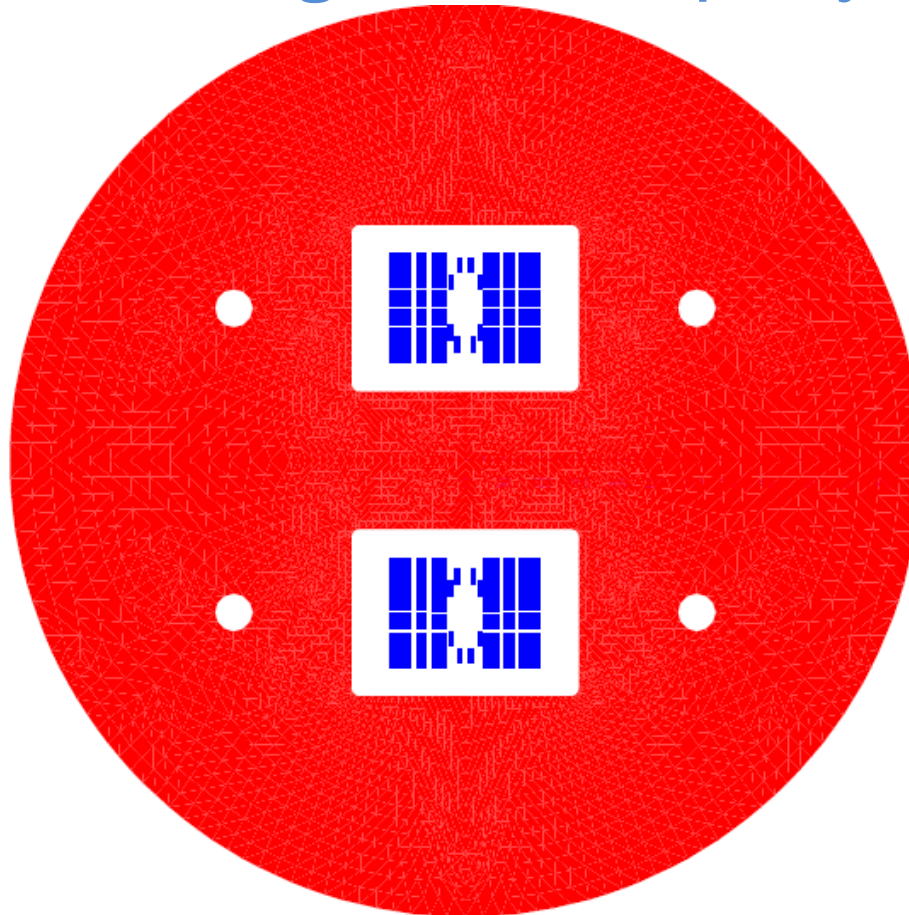
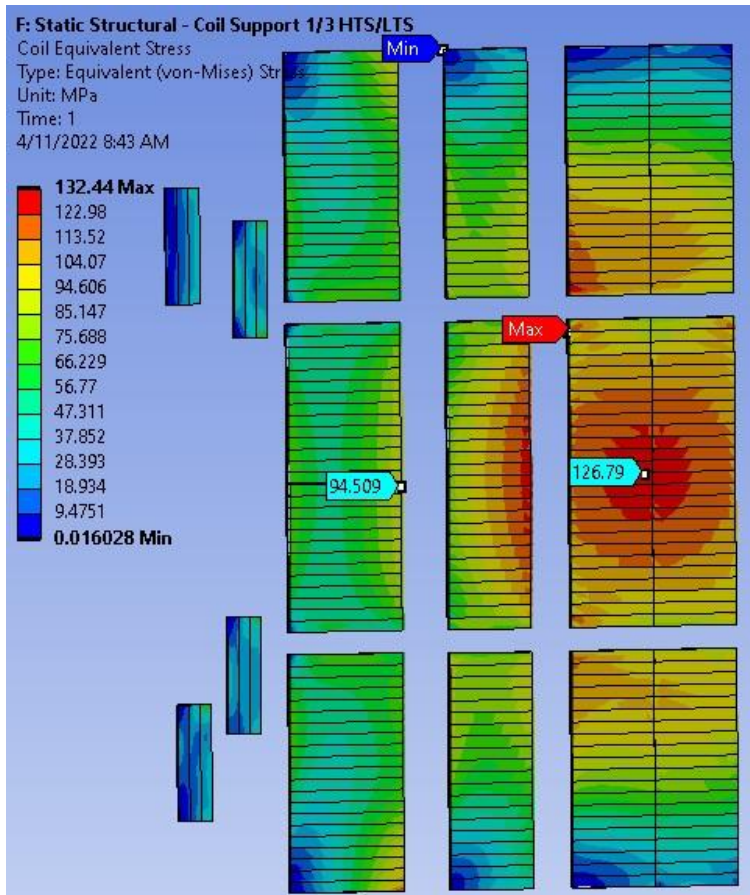

|B| (T)

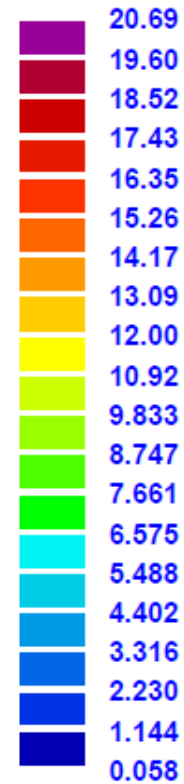

ROXIE₁₀

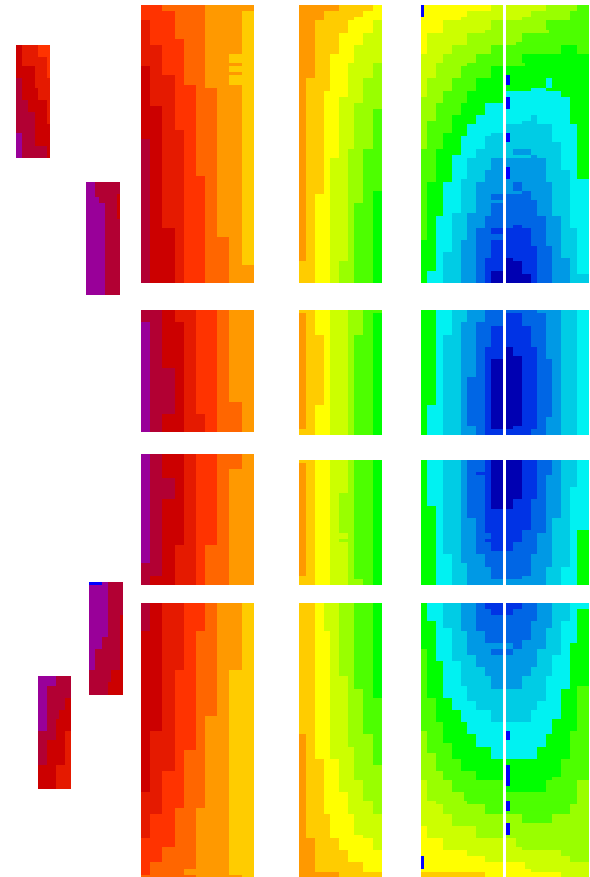



Strategy Behind the Mechanical Structure (taking advantage of the force distribution)

Key Components of Structure: Vertical Plates, Spacers (sliding surface), Springs, Collars
New Design: Forces @20 T, Note: additional spacers at midplane

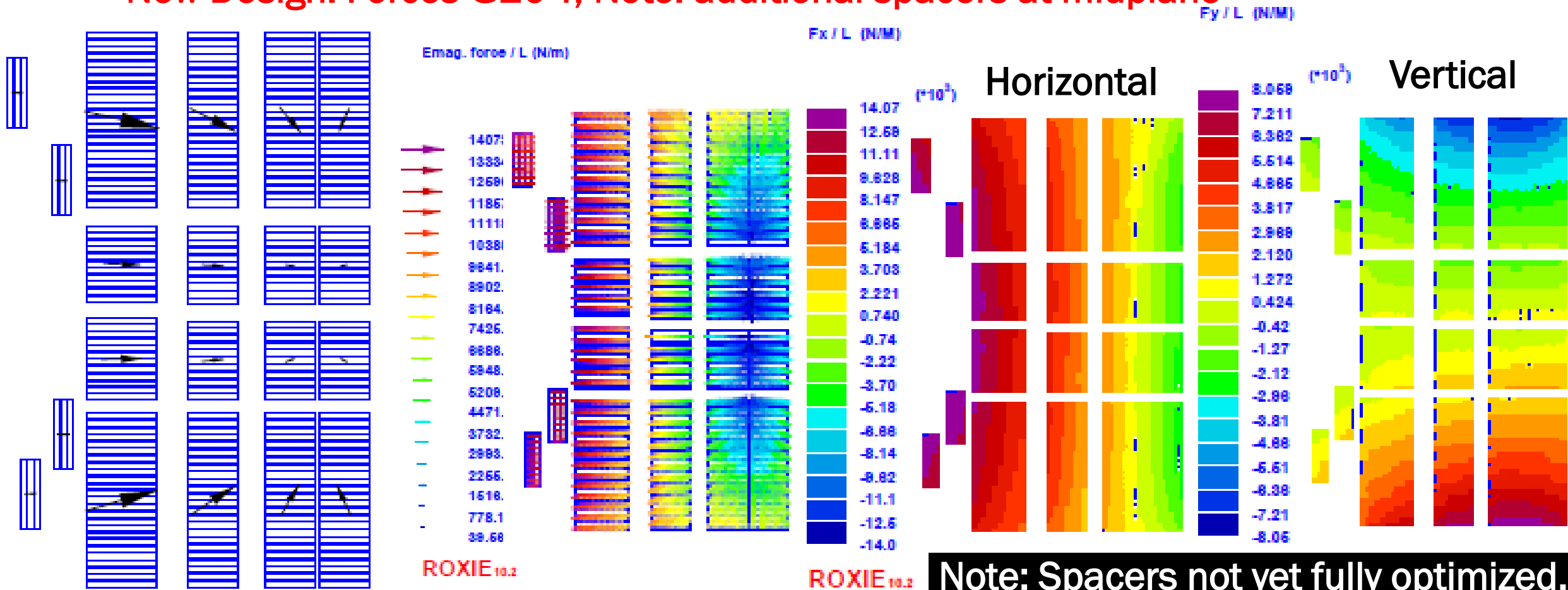



Magnetic Design (May 2022) with 15% Margin

	I(HTS), A	I(Nb3Sn)	Je(HTS), A/mm ²	Jo(HTS), A/mm ²	Je(Nb3Sn)	Jo(Nb3Sn)	Bo (T)	Bpk(HTS), T	Bpk(Nb3Sn)	
	0	0	0	0	0	0	0	0	0	
	13600	13600	487.60	400.672	639.10	526.316	19.938	20.695	13.670	
	1.0031	13642.2	13642.2	489.107	401.914	641.079	527.947	20.000	20.759	13.712
	1.15355	15688.3	15688.3	562.465	462.195	737.231	607.132	23.000	23.873	15.769

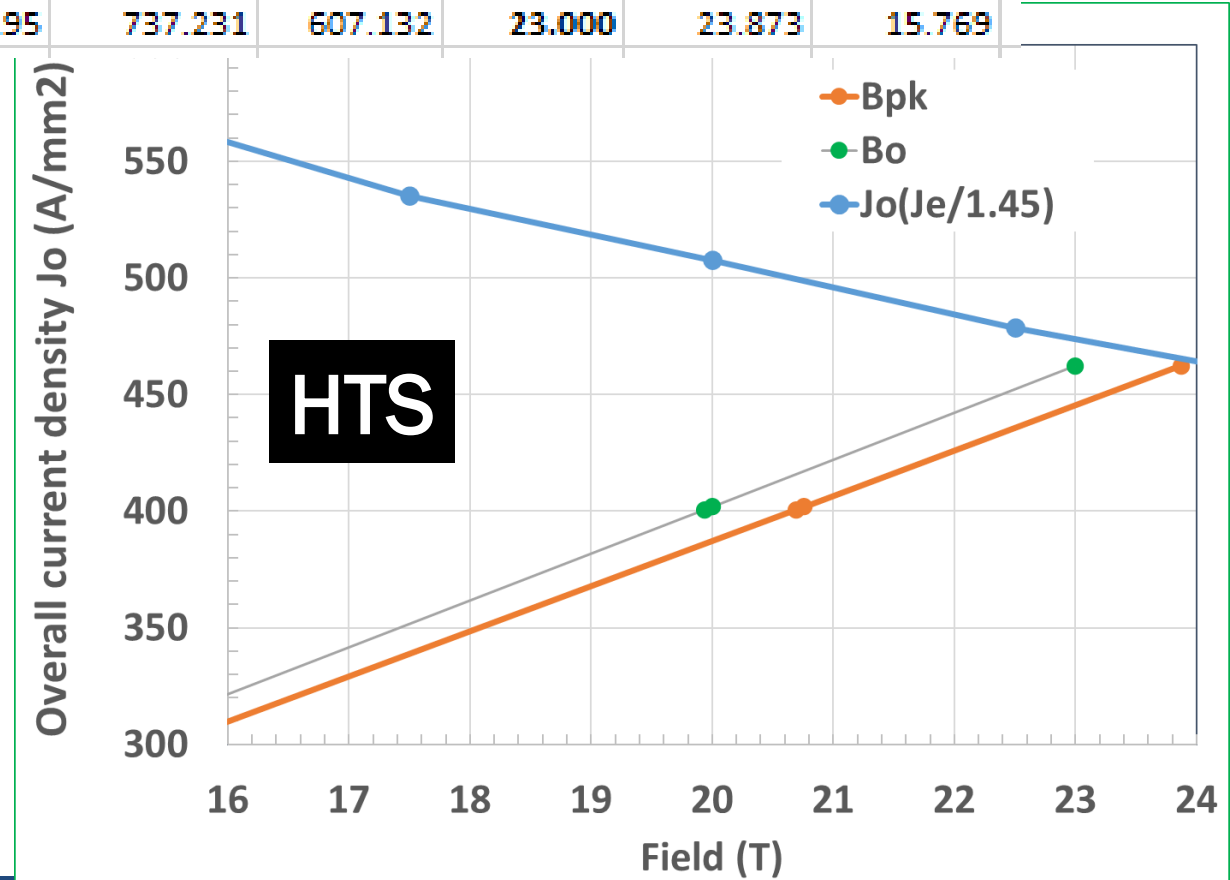
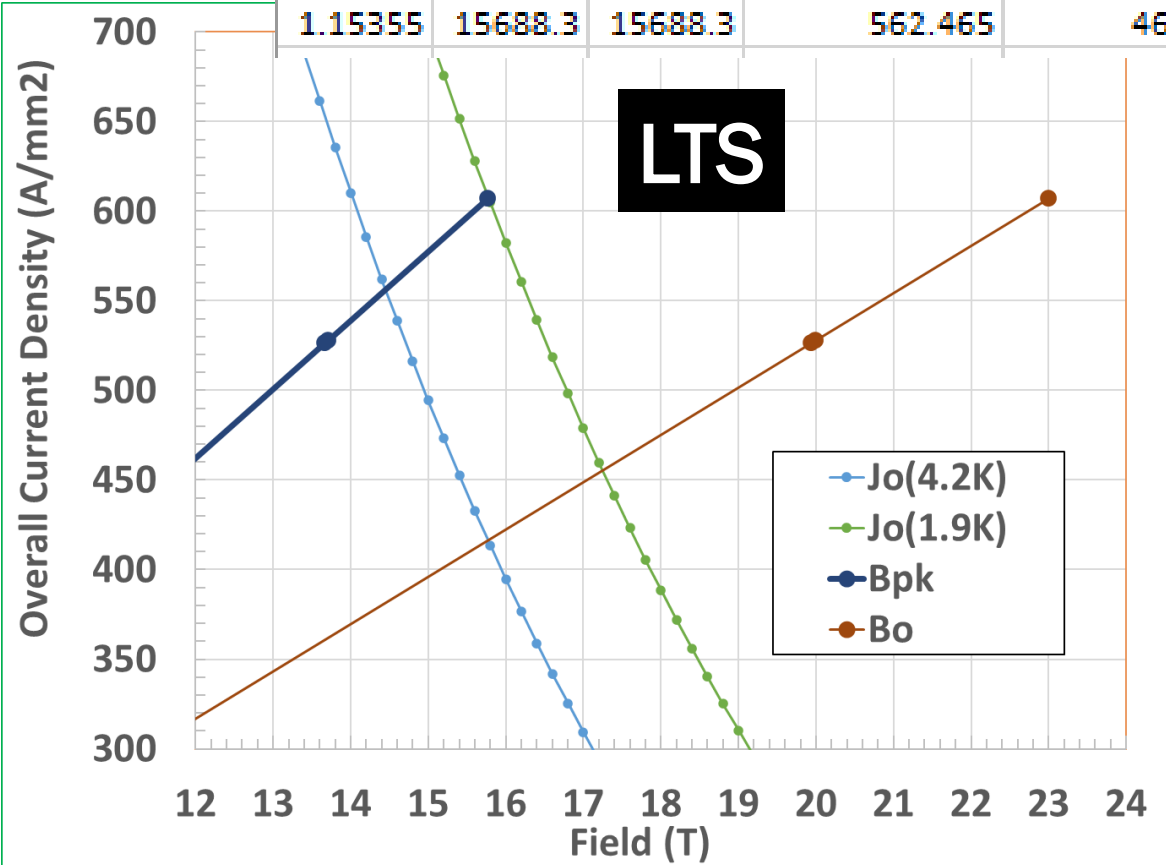



Magnetic Design (May 2022) Good Field Quality

MODEL	mdp_may2022-v2
BI2212R	Bi2212
Bare w	1.52
Bare h	18.35
Insulation	0.15
Ins w	1.82
Ins h	18.65
Ins Area	33.943
Current	13600
Je (A/mm ²)	487.60
Jo (A/mm ²)	400.67
Bpeak (T)	20.6951
MDPH2	Nb ₃ Sn
Bare w	1.6
Bare h	13.3
Insulation	0.15
Ins w	1.9
Ins h	13.6
Ins Area	25.840
Current	13600
Je (A/mm ²)	639.10
Jo (A/mm ²)	526.32
Bpeak (T)	13.6701
Bo	19.9382

NORMAL RELATIVE MULTIPOLES (1.D-4) :

b 1:	10000.00000	b 2:	-0.00000	b 3:	0.05059
b 4:	-0.00000	b 5:	0.09440	b 6:	0.00000
b 7:	-0.78244	b 8:	0.00000	b 9:	-0.92602
b10:	0.00000	b11:	-0.18313	b12:	-0.00000
b13:	-0.02800	b14:	0.00000	b15:	-0.01273
b16:	0.00000	b17:	-0.00410	b18:	-0.00000
b19:	-0.00094	b20:	0.00000	b	

SKEW RELATIVE MULTIPOLES (1.D-4) :

a 1:	0.00000	a 2:	-0.00405	a 3:	0.00000
a 4:	-0.02333	a 5:	-0.00000	a 6:	-0.15914
a 7:	0.00000	a 8:	0.20675	a 9:	0.00000
a10:	0.08678	a11:	-0.00000	a12:	0.00779
a13:	0.00000	a14:	0.00593	a15:	-0.00000
a16:	0.00258	a17:	0.00000	a18:	0.00056
a19:	-0.00000	a20:	0.00019	a	

Next Steps (one slide each)

Analytic

- Quench analysis
- Structure and assembly concept
- 3-d magnetic and mechanical design and analysis

Proof-of-Principle (low cost)

- Pole or field shaping coils (relatively more complex)
- Test pole coils as insert coils as an integral part of the DCC017 structure
- Two Phase I SBIR were funded for two geometries. Practice coil wound but not tested as Phase II weren't funded
- Test those and/or other geometries as a part of the MDP. These coils can be designed and built at any lab.
- Toy models of mechanical structure



A Possible Structure Concept

Shims to control horizontal pre-stress

Shims to control vertical pre-stress

Spacers/Wedges
Sliding contact

(horizontal Lorentz forces are transferred to the collar via the spacers and not through the coils)

Peter McIntyre Style

Spring
(or softer material)

Collars to apply a modest horizontal and vertical pre-load

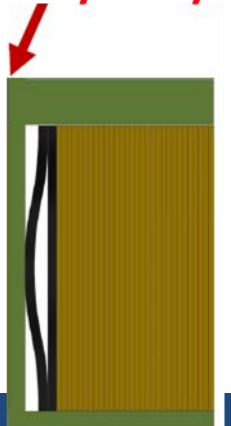
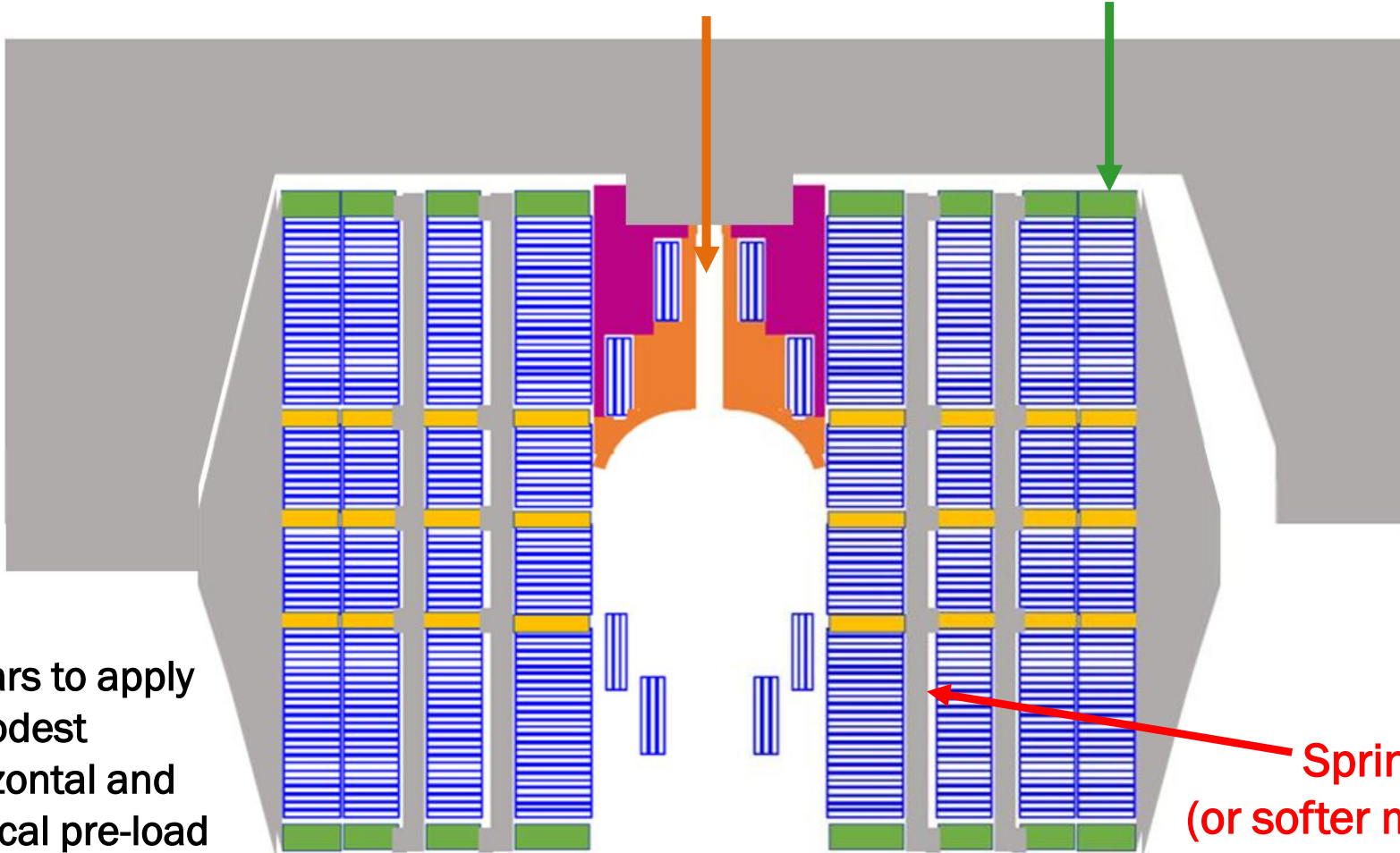



A Few Possible Layouts of Pole Coils Clearing the Bore (other geometries shown elsewhere)

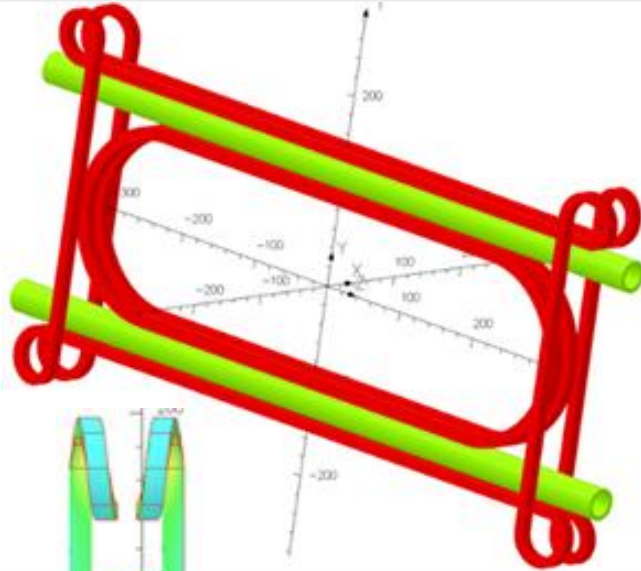
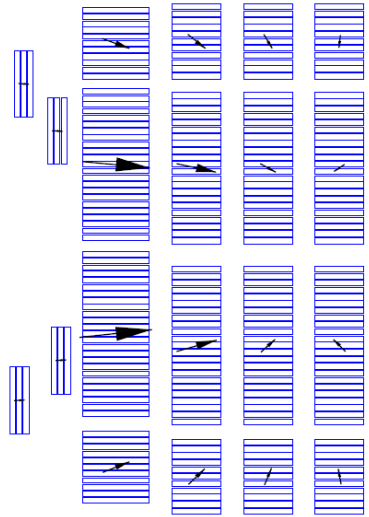

Practice pole coil windings and preliminary designs (performed under three SBIR Phase I; no Phase II). They can be built and tested under MDP.

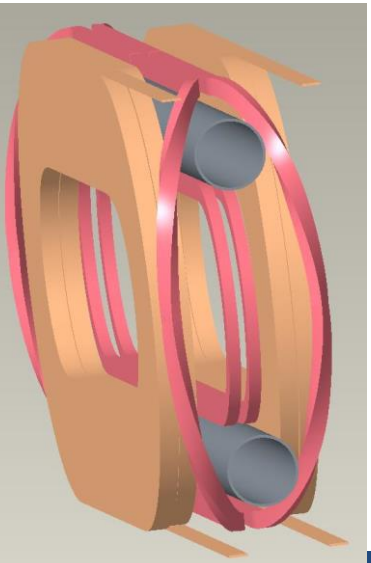
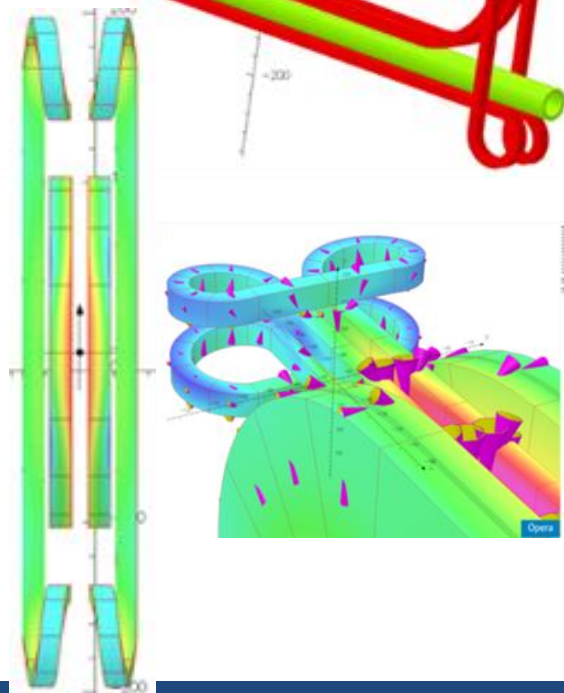
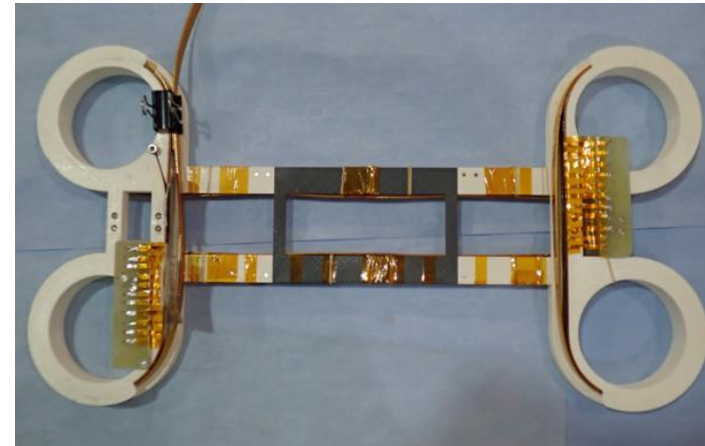



Extra Slides

Key Benefits of the Common Coil Design for HTS/LTS High Field Hybrid Dipoles

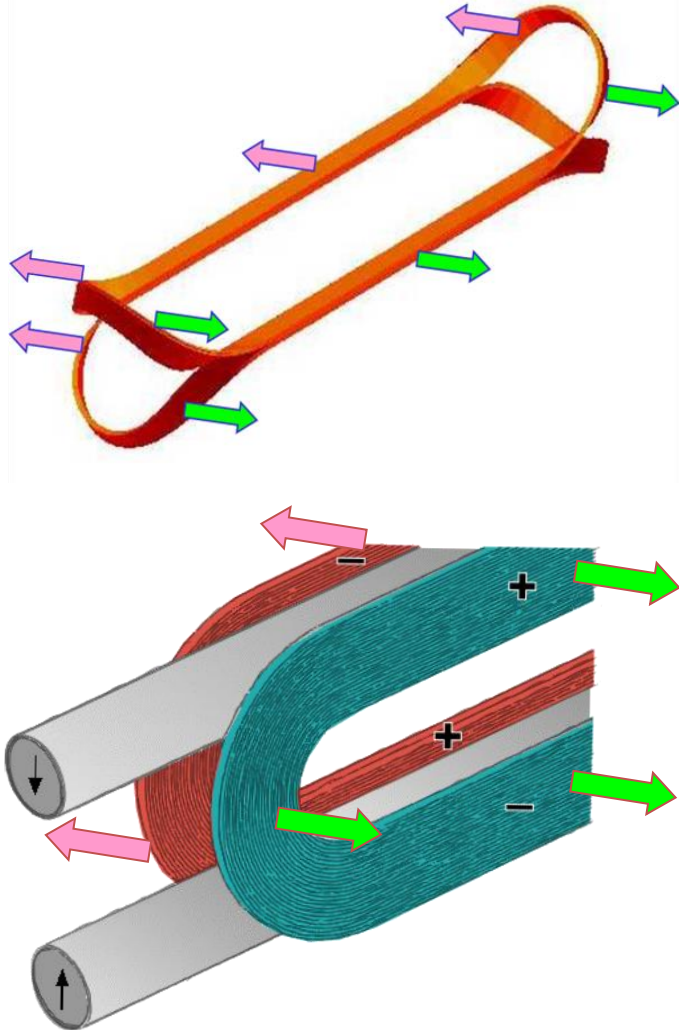

- ❑ Coil layers move as a module without causing strain at ends (BNL common coil had 200 μm). This should also save on the structure needed
- ❑ Flexible space for stress managed structure
- ❑ Natural segmentation between HTS and LTS for efficient optimization of conductor usage
- ❑ Simple coil geometry with large bend radii allow more technologies (W&D, R&W), more cables, more materials, etc.
- ❑ Modular design for low-cost, fast-turn-around R&D (PoP: 12.3 T MDP HTS/LTS hybrid dipole)

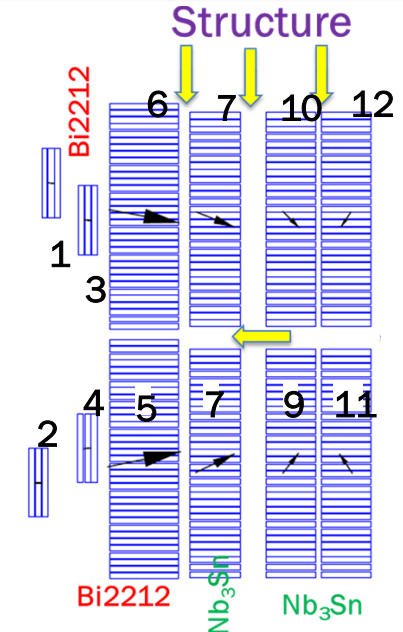



A Few Possible Layouts of Pole Coils Clearing the Bore (other geometries shown elsewhere)

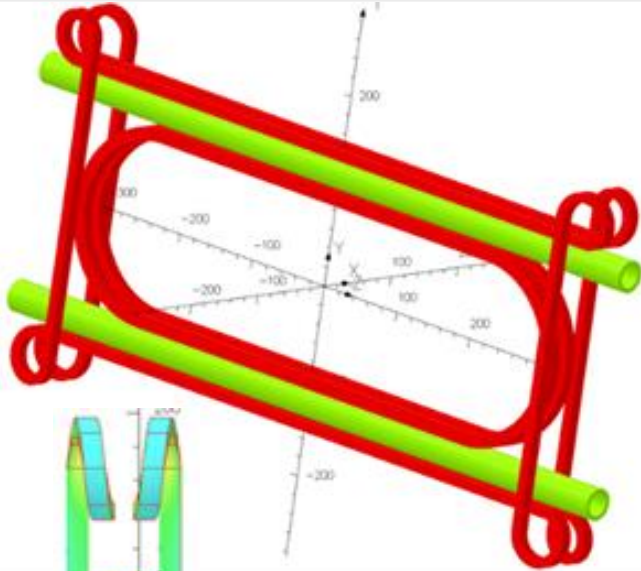
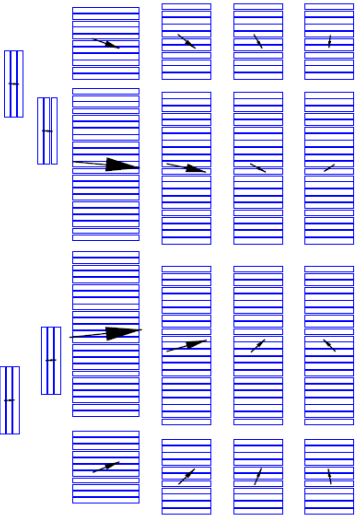

Practice pole coil windings and preliminary designs (performed under three SBIR Phase I; no Phase II). They can be built and tested under MDP.

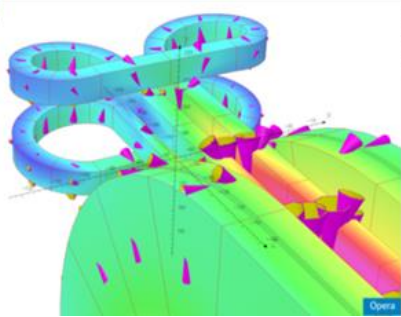
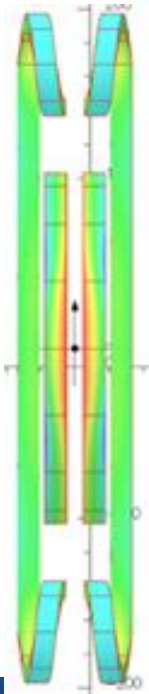
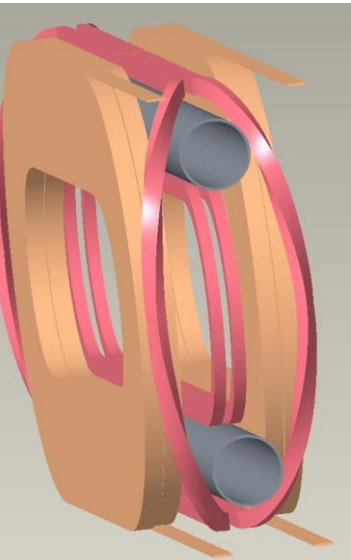
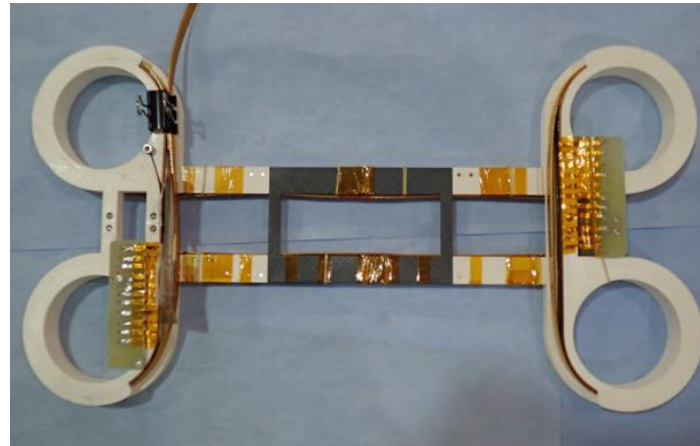



Splices in Common Coil Design (between two single layer coil)

In common coil design, splice (even between two types of coils), can be easily made in the middle of the coil where the field is very low

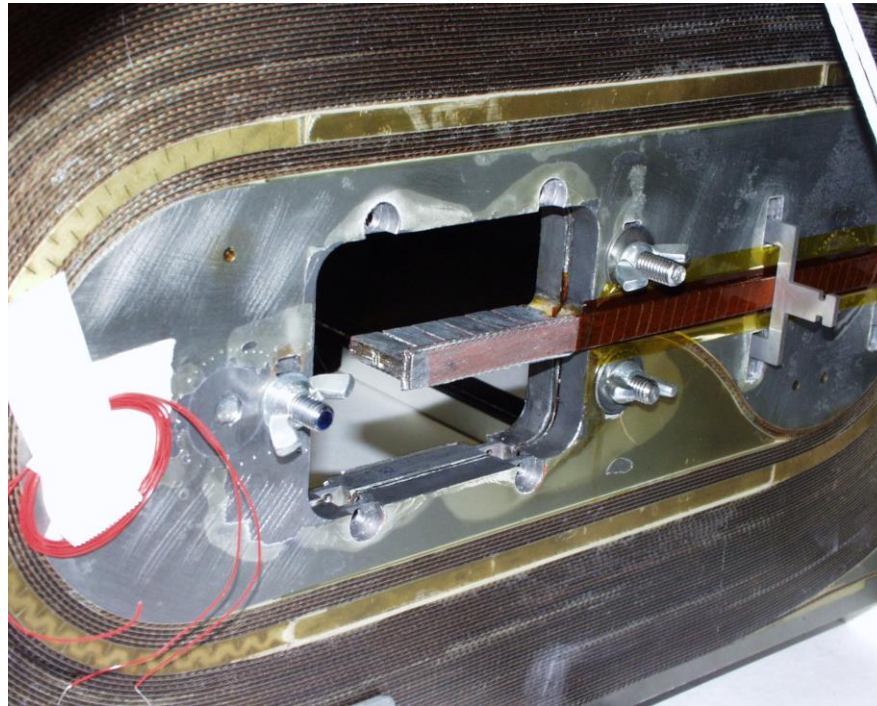
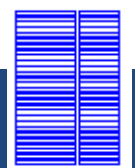
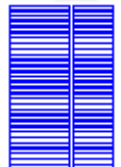
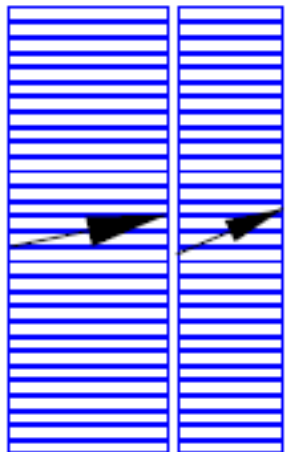
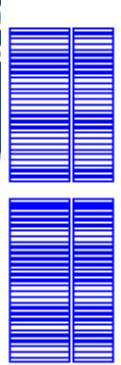
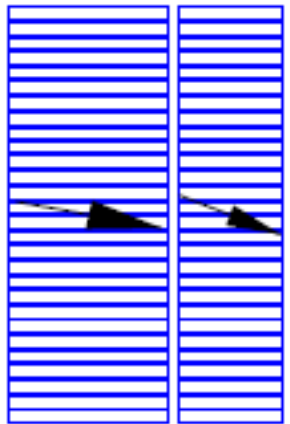

Perpendicular Nb-Ti splice in the low field region of BNL common coil dipole DCC017

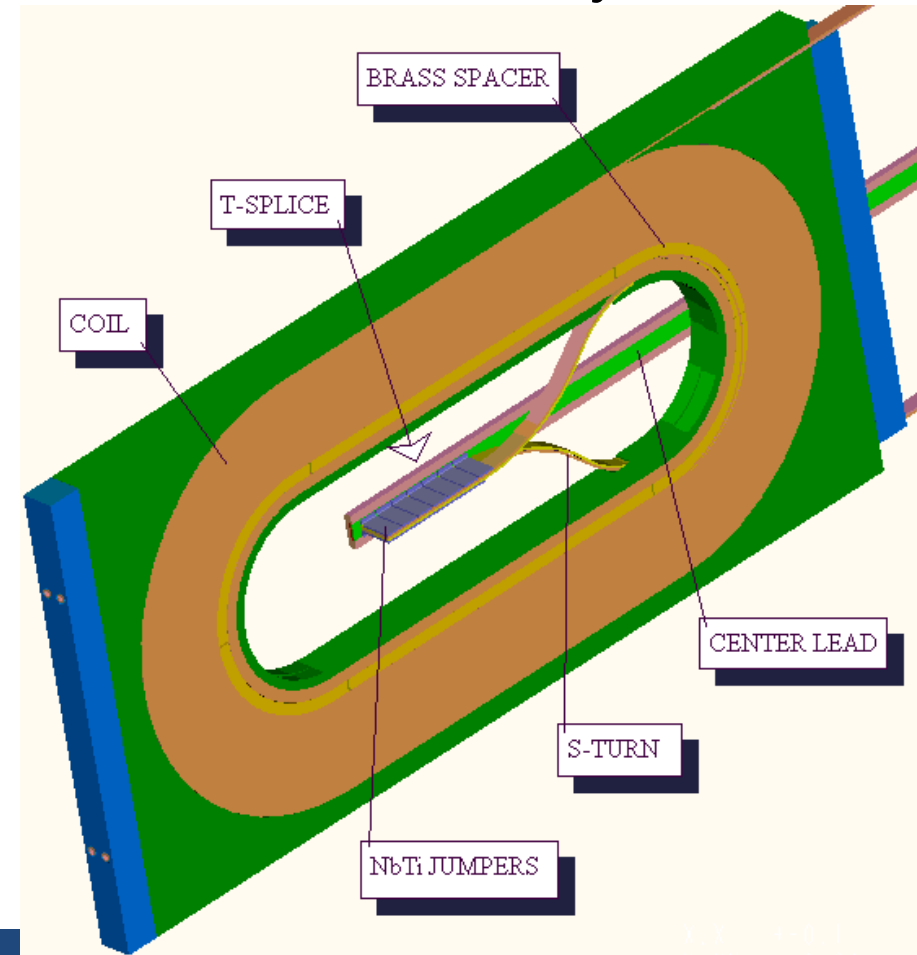

-Ramesh Gupta, BNL

June 14, 2022



New 20 T HTS/LTS Hybrid Design (May 2022)

(spacers in magnetic design takes input from mechanical)

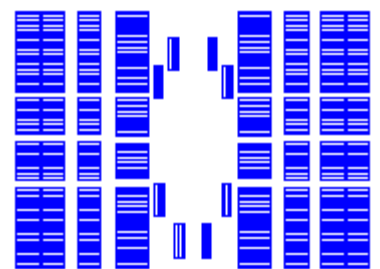
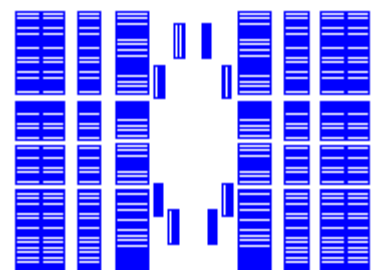
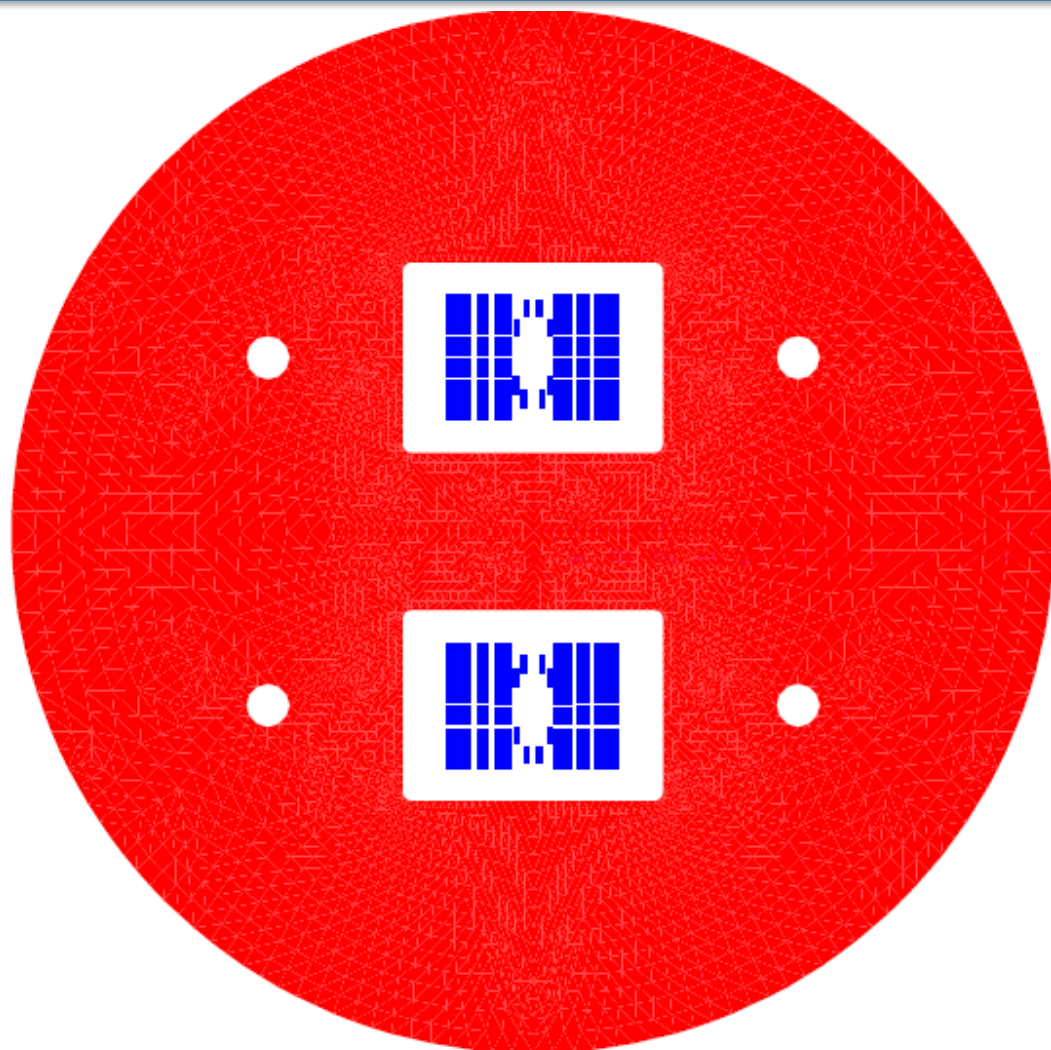

$|B|$ (T)

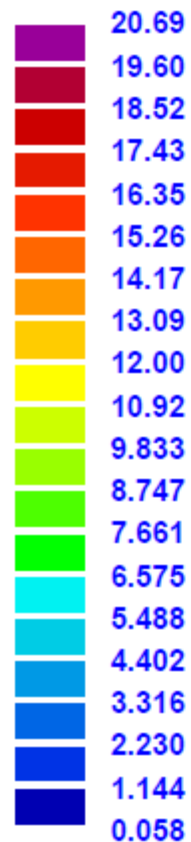

ROXIE_{10.2}

